



**WITH YOU
SUCCESS TOGETHER**



TC-20α SERIES
Drilling & Tapping Center



HEADQUARTERS
No. 186, Yong Chi Road, Taipei, Taiwan.
Tel: +886-2-2763-9696
Fax: +886-2-2768-0636/37/39
www.ffg-tw.com
E-mail: chairom@fairfriend.com.tw



FEELER MACHINE TOOLS DIVISION
No. 12, Jingke Rd., Nantun Dist., Taichung City, Taiwan
Tel: +886-4-2359-4075
Fax: +886-4-2359-4873
www.feeler.com
E-mail: sales@feeler.com



Website



Facebook

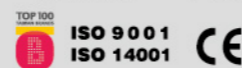

19.05.1000.S601000001



TC-20α offers the advanced Features for more Accurate and efficient operations.

The TC-20α Drilling & Tapping Center from Fair Friend is designed and manufactured to offer outstanding efficiency in drilling and tapping. It integrates many improved and fine features which gain Fair Friend's TC-20α a reputation for dependable high productivity and high accuracy. Its rugged construction is manufactured from high quality cast iron, assuring excellent toughness and excellent vibration absorption.



TC-20α

- This model is designed for light and tiny workpiece as well as for machining of diverse patterns with less quantity.
- Delicately, rigidly designed structure provide excellent accuracy at high speed running.
- Linear guides on 3 axes.
- 12,000/15,000 RPM provides additional efficiency in drilling operations.
- A choice of 14-tool turret-type ATC or 20-tool arm-type ATC to meet your machining requirements.

Machine Features

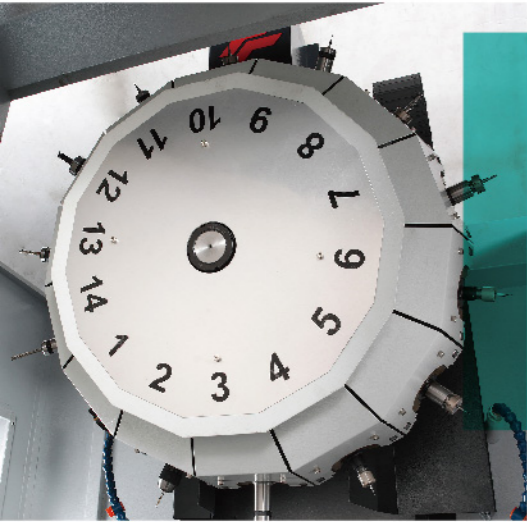

Turret-type ATC

- Magazine for 14 tools.
- Tools of 7/24 taper are applicable; both clockwise and counter-clockwise rotation available for high efficiency tool selection.

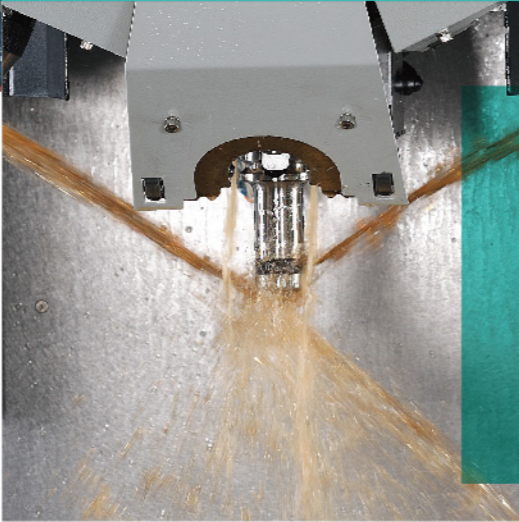

Dual Flushing

- High volume flushing for longer tool lifetime.
- Flushing nozzles set at side for least interference with the 4th axis.



Large Cooler Tank

The cooler tank capacity is 200L.

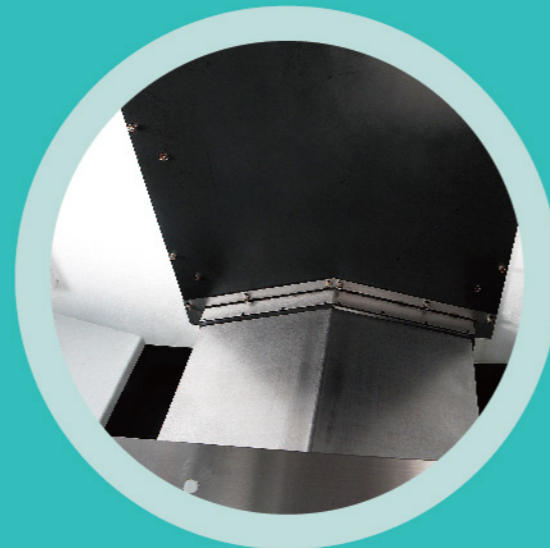

Effective Protection

Single-piece axial cover on Z/Y axes feedrate and lifetime.



Self-lube System

Automatic lubrication for extended machine lifetime.



Pneumatic System

The pneumatic system is set externally for easy check and maintenance.



Dust-Proof Electrical Cabinet

Rubber seals are mounted at the EC cabinet door for enclosure.



Enhanced Coolant and Chip Discharge

2 tilting discharge channels along with large cooler tank speeds up exhaust of coolant and chips.



Enlarged Window

Easier maintenance on X axial servomotor, guideways and ball screw.

DIRECT DRIVE SPINDLE - SPINDLE TORQUE DIAGRAM

MACHINE LAYOUT/WORKING TABLE DIMENSIONS

◆ Spindle Motor (D.D.S 12,000 rpm)

Power/Torque characteristic of SIEMENS 1PH8083 for spindle 12000rpm-

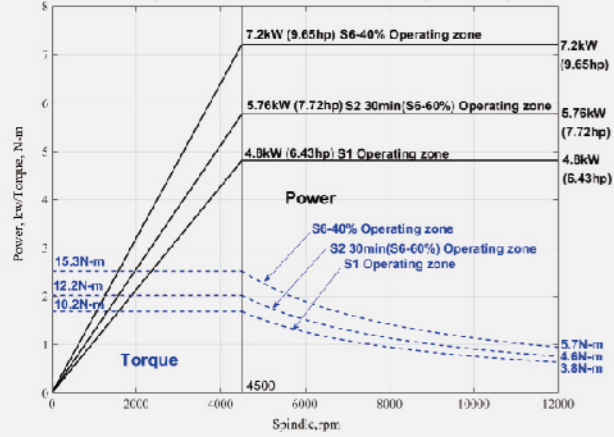

◆ Spindle Motor (D.D.S 15,000 rpm)

Power/Torque characteristic of SIEMENS 1PH8083 for spindle 15000rpm-

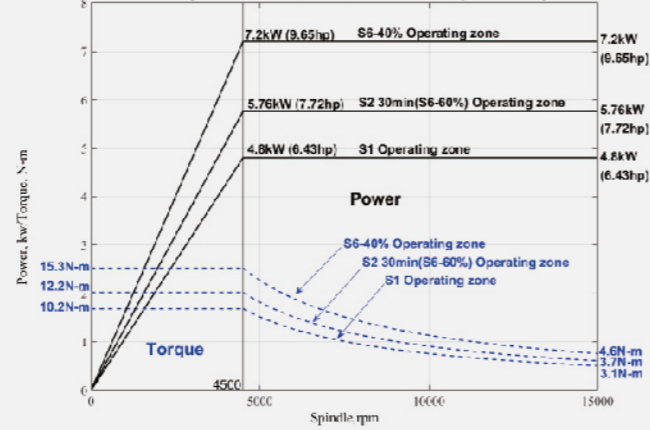

Power/Torque characteristic of FANUC A3/12000i for spindle 12000rpm-

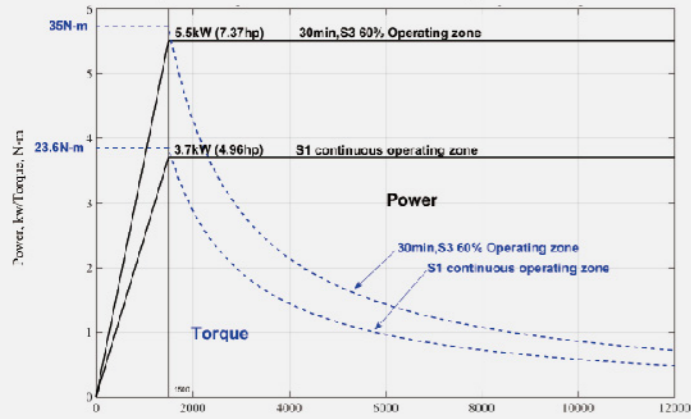

Power/Torque characteristic of FANUC a2/15000i for spindle 15000rpm-a2/15000i

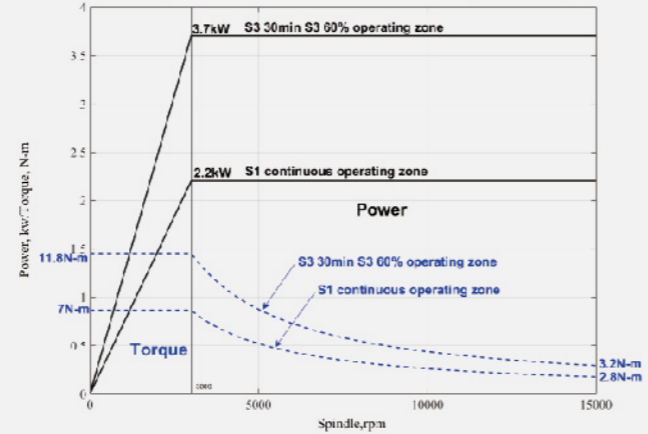

Power/Torque characteristic of MITSUBISHI SJ-DJ5.5/12000 for spindle 12000rpm-

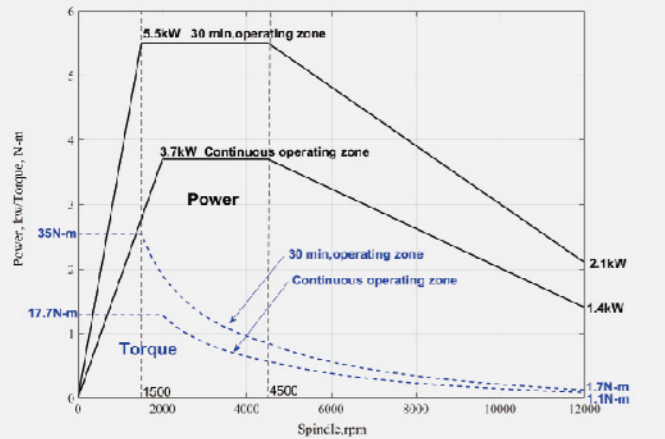

Power/Torque characteristic of MITSUBISHI SJ-DL5.5/20000 for spindle 15000rpm-

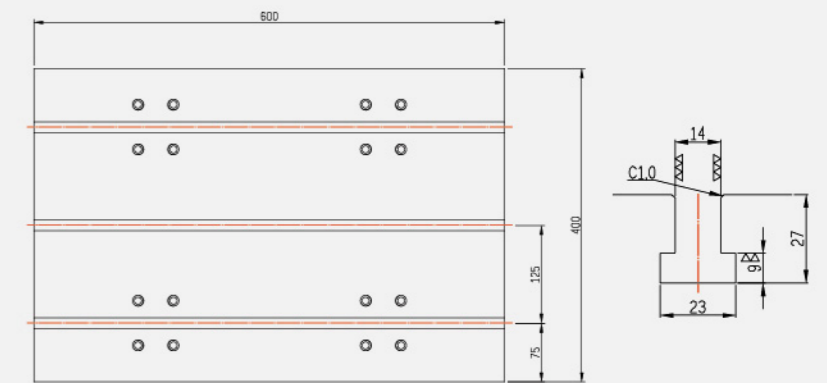
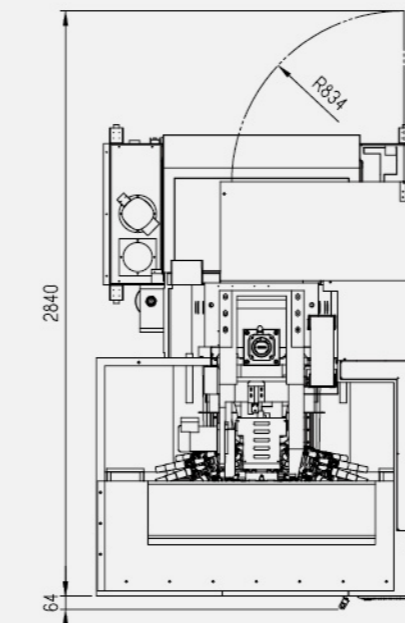
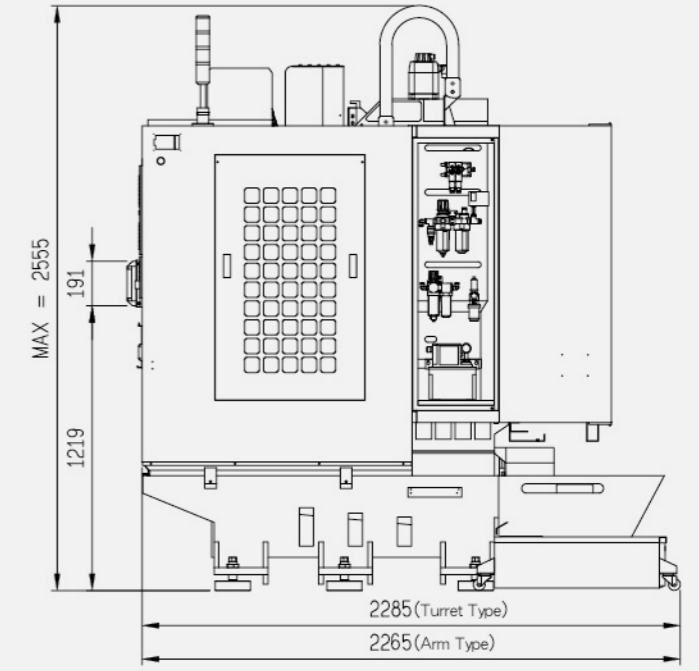
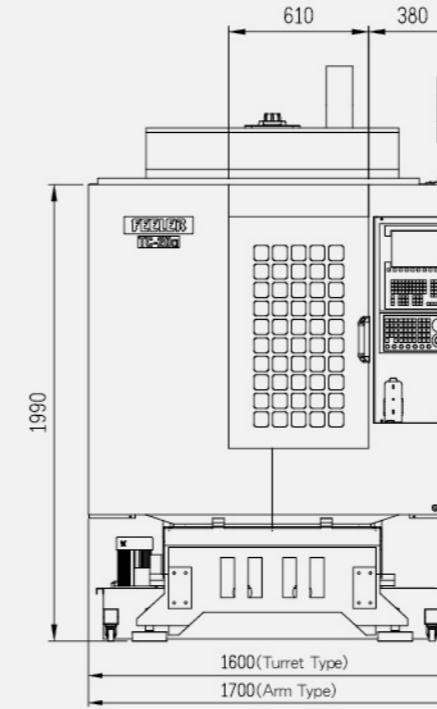
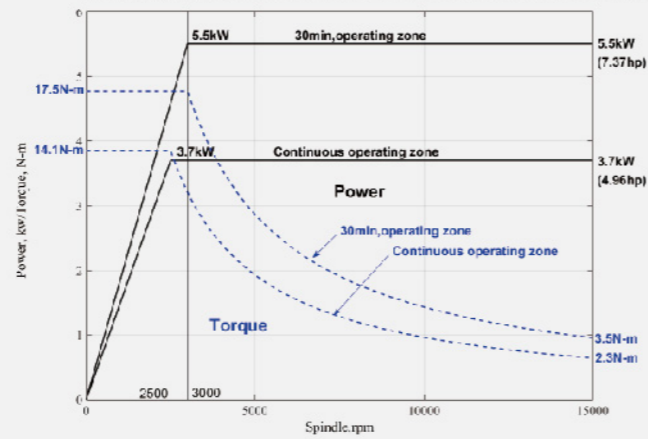

MACHINE SPECIFICATIONS

	Unit	TC-20α Turret Type/Arm Type
TRAVEL		
X axis travel	mm	510
Y axis travel	mm	400
Z axis travel	mm	300 / 400
Spindle nose to table surface	mm	174~474 / 174~574
Table surface to floor	mm	845
TABLE		
Table dimension	mm	600x400
Max.loading weight	kg	250
T-slots(WxNO.xP)	WxNO.xP	14x13x125
SPINDLE		
Spindle speed	rpm	12,000
Spindle nose		7/24Taper No.30
Spindle motor	kw	3.7 / 5.5
FEEDRATE		
Rapid traverse X axis	m/min	48
Rapid traverse Y axis	m/min	48
Rapid traverse Z axis	m/min	48
AUTOMATIC TOOL CHANGER		
No.of tools	T	14 / 20
Pull stud		P-30T(45°)
Max.tool weight/total tool	kg	3/25
Max.tool length	mm	200
Max.tool diameter	mm	Ø 80
Tool changing time (tool to tool)	sec	1.8
OTHERS		
Floor space	mm	1,600x2,285 / 1,700x2,285
Machine weight	kg	2,400
Max.machine height	mm	2,555
Power capacity	KVA	15
Air source	Bar	6~8

*Specifications are subject to change without prior notice.

MACHINE ACCESSORIES

	TC-20α Turret Type/Arm Type
3-Axis Pre-tensioned Ball Screw	●
3-Color Signal Light	●
Automatic Lubrication System	●
Coolant Nozzles	●
Dust-Proof Electrical Cabinet	●
Enclosed Splash Guard	●
Ethernet Interface	●
Front Door Inter Lock	●
Heat Exchanger	●
Outside Air Blast	●
Rear Side Chip Flushing System	●
Rigid Tapping	●
RS232	●
Spindle Air Sealing	●
Spindle Coolant Nozzle	●
Spindle Oil Cooler	●
Spindle Speed DDS 12000rpm	●
Spindle Taper BT30	●
Work Light	●
14T - Turret Type ATC	●
20T - Arm Type ATC	○
4th Axis Interface	○
Air Condition	○
Air Gun	○
Auto Tool Length Measurement	○
Auto Workpiece Measurement	○
Automatic Power Off	○
C.T.S with filter system(top roof must included)	○
Chip Conveyor-Left/Right Side Discharge & Chip Bucket	○
Chip Flushing System	○
Column Raiser 150mm	○
Coolant Gun	○
CTS Interface	○
Linear Scale	○
Oil Skimmer	○
Screw type Chip Conveyor-Left/Right Side Discharge & Chip Bucket	○
Spindle air blast	○
Spindle Speed 15000/20000 rpm(DDS)	○
Top Roof	○

●:Standard ○: Optional