

型號	MODEL	BSM 80 / BSM 80L
材料長度	BAR LENGTH	1.2M / 1.5M
材料外徑	MATERIAL DIAMETER	5 ~ 80 mm
棒材置料量	BAR CAPACITY	80mm (7bars)
機械寬度	MACHINE WIDTH	1018.1mm
機械重量	MACHINE WEIGHT	1.2M - 360 KG / 1.5M - 400 KG
主馬達	MOTOR	伺服馬達 SERVO MOTOR
主電力	POWER SUPPLY	1 x 220v 60hz / 1 x 380v 50hz
消耗功率	POWER CONSUMPTION	615W

若需要其他資料請上網查詢 Check our website for more details Web Site: www.barload.com.tw

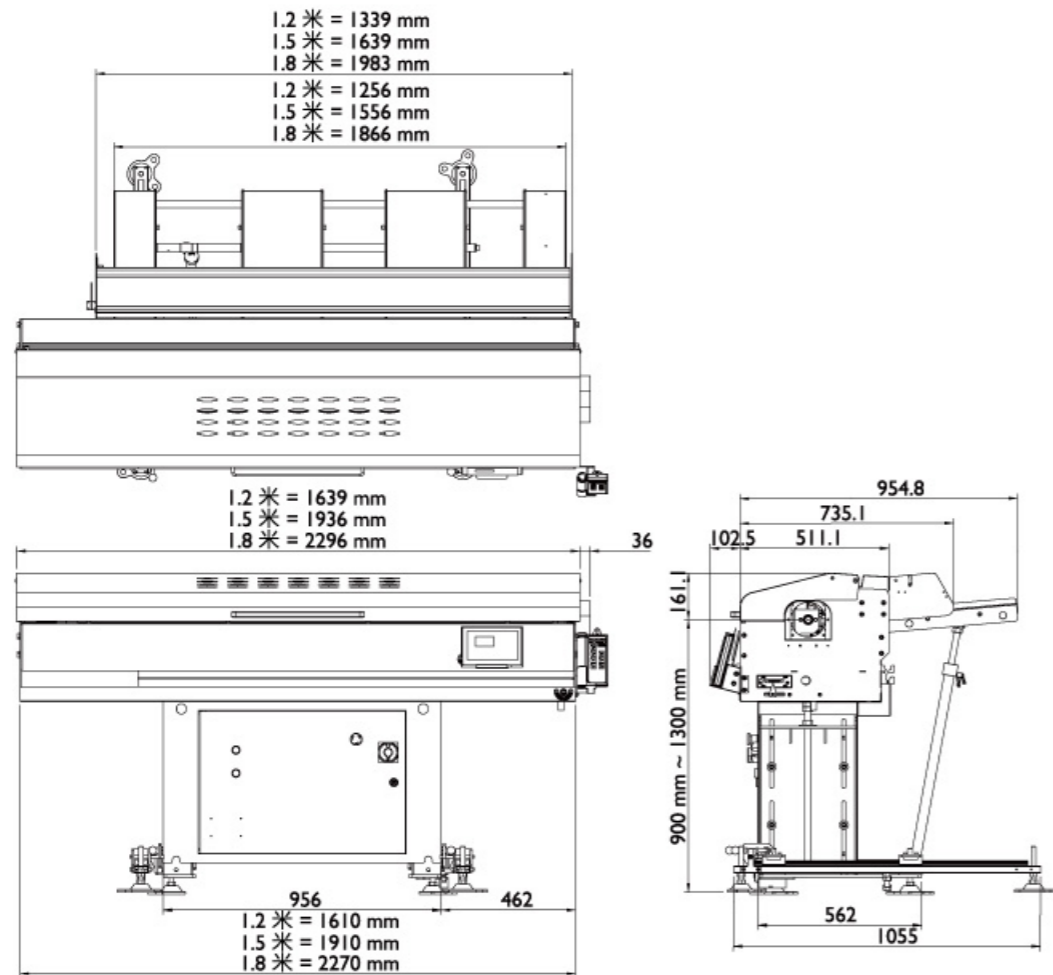

富豪機電股份有限公司
BARLOAD MACHINE CO., LTD.

No. 138, Wei-Hsin Road, Shi-Pai Li, Chang-Hua City, Taiwan 50080
 50080彰化市石牌里維新路138號
 TEL: +886-4-7384895 FAX: +886-4-7320282
 E-mail: info@barload.com.tw

www.barload.com.tw

經銷商 Agent

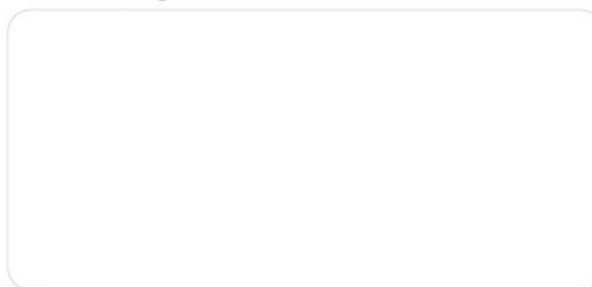

本公司保留設計變更的權利 All Rights Reserved.

16228501502CE



www.barload.com.tw



創新研發 · 台灣領航
 品質追求 · 世界第一

Quality Innovation
 Reliability Experience



BSM 80
 系列 Series
 5 - 80 mm

SHORT BAR FEEDER

短棒材送料機

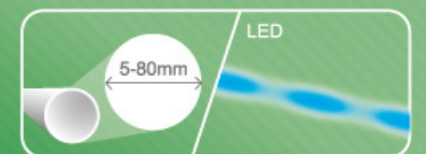



LED遠端監控 LED-stripe Display Features Operative Status

- ▶▶ LED燈光外部顯示器，送料加工中棒材長度、換料、送料機異常、車床異常等訊息經LED燈光顯示以視覺表現，方便工作人員遠距離監控。(專利)
- ▶▶ Equipped with LED external display. During bar feeding, various messages such as "bar length", "bar change", "feeder error", and "CNC lathe error" are more easily identified, permitting remote monitoring. (Patented)



智慧型人機介面 Fuzzy Human Machine Interface

- ▶▶ 人機界面，設定簡易操作容易；人性化控制，異常故障排除容易。
- ▶▶ HMI display provides easier operation setting and quick trouble shooting.

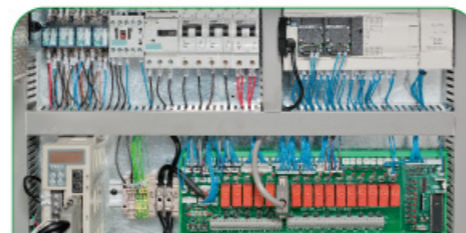

電控系統 Electrical System

- ▶▶ 內部PLC控制，易與任何CNC車床搭配。
- ▶▶ Servo control system for fast speed and accuracy.



手控器 Movable Remote Controller

- ▶▶ 手控盒，易於操作，符合人體工學。
- ▶▶ Hand held remote control greatly increases operator control on machine.



移動式腳座 Retraction device (Movable Rail)

- ▶▶ 移動式腳盤，方便主軸維修，更換皮帶，主軸襯套。
- ▶▶ Movable rail, convenient for machine service, changing belt or spindle liner.



伺服馬達 Servo Motor

- ▶▶ 伺服馬達送料快、準、順暢。
- ▶▶ Servo feeding fast and accurate, no risk of impact by the bar on the lathe clamping cylinder.

- 提高CNC車床加工密度與加工速度。
- 黑皮材料，六角材料適用。
- 伺服送料系統人機設定穩定精確。
- 更換材料時，材料中心人機設定調整。
- 全電式，無氣壓。
- LED燈可顯示加工中材料長度與CNC車床或送料機之異常顯示。
- 已通過CE認證。

- Increases speed and accuracy for CNC lathe.
- Servo feeding system. Fast and accurate.
- All electrical control mechanical driving transmission, no air required.
- External LED display, easier to monitor feeding situation.
- Fast bar change time less than 15 sec.
- CE certificated.

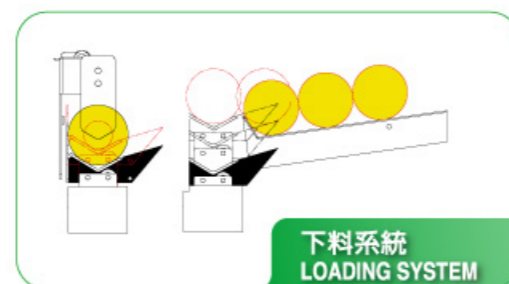

下料系統
LOADING SYSTEM



BSM 80 系列 Series

SHORT BAR FEEDER

短棒材送料機