

Angle heads

Têtes à renvoi d'angle / Winkelköpfe

MADAULA
creative solutions



“Perfect work requires passion, precision
and well designed and reliable tools.

Madaula focus
is to supply these tools to world-wide industry”



Sistema de
Gestión
ISO 9001:2015



www.tuv.com
ID 9105079298

Tradition in precision

Since 1956 **Madaula** has stood for the highest quality and the best reliability of its products.

We have more than 55 years of experience in design, development and manufacture all kind of heads for the machine tool industry.



Depuis 1956, **Madaula** est synonyme de la plus haute qualité et de la meilleur fiabilité pour ses produits. Nous avons plus de 55 ans d'expérience dans la conception, le développement et la fabrication de tous types de têtes pour l'industrie de la machine-outil.

Seit dem Jahr 1956 steht das Unternehmen **Madaula**. für höchste Qualität und Zuverlässigkeit ihrer Produkte. Wir besitzen mehr als 55 Jahre Erfahrung in Design, Entwicklung und Herstellung aller Art von Köpfen für die Werkzeugmaschinenindustrie.



Innovation and reliability

We're focused on our ability to create products adapted to our customer's needs, reduce their manufacturing cost, thereby improving their competitive edge in the market.

We work to ensure optimally designed, precise, robust and durable products.

We love challenges.

Our goal is to turn your vision into reality and thereby increase your productivity.

Nous nous sommes consacrés sur notre capacité à créer des produits adaptés aux besoins des clients, à réduire leurs coûts de fabrication et ainsi améliorer leur avantage compétitive sur le marché.

Nous travaillons pour créer des produits de conception optimale, durables, robustes et précis.

Nous aimons les défis.

Notre objectif est d'augmenter votre productivité.

Im Mittelpunkt unserer Überlegungen steht unsere Fähigkeit, Produkte herzustellen, welche den Bedürfnissen unserer Kunden gerecht werden. Dabei verfolgen wir das Ziel, die Herstellungskosten unserer Kunden zu senken, um somit ihre Wettbewerbsfähigkeit auf dem Markt zu erhöhen. Wir arbeiten stets daran, Ihnen optimal konzipierte, präzise, sowie robuste und langlebige Produkte zu gewährleisten.

Wir lieben Herausforderungen. Unser Ziel ist es, Ihre Vorstellungen in die Realität umzusetzen und dadurch Ihre Produktivität zu steigern.

All over the world



Our head office and factory are located in Barcelona, recognized city throughout the world by the creativity and constant innovation of its industries.

We sell all over the world with subsidiaries in Germany, USA, Italy, Brazil and India, with representatives all over the world. We export the 80% of our production.

Notre siège social et l'usine sont situés à Barcelone, ville reconnue mondialement par sa la créativité et constante innovation. Nous vendons partout dans le globe avec des filiales en Allemagne, USA, Italie, Brésil et l'Inde, et avec des représentations dans le monde entier. Nous exportons le 80% de notre production.

Unser Hauptsitz und Produktionsstätte befinden sich in Barcelona, einer Stadt, welche weltweit für ihre Kreativität und ständige Innovationen bekannt ist. Wir vertreiben unsere Produkte auf der ganzen Welt durch unsere Tochtergesellschaften in Deutschland, USA, Italien, Brasilien und Indien und durch unsere Vertretungen weltweit. 80% unserer Produkte werden exportiert.

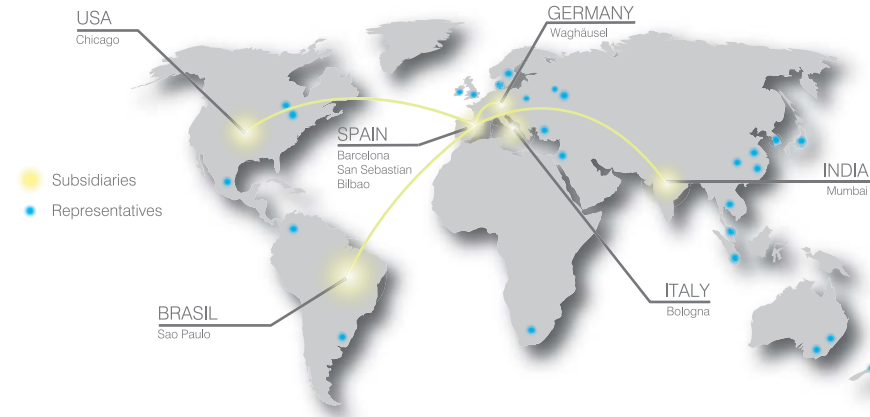

Manufacturing facilities

We welcome you to our facilities. Madaula has a continuous improvement policy, we invest to improve our technical production, assembly and quality departments.

Soyez les bienvenus dans nos nouvelles installations. Madaula investit constamment afin d'accroître sa capacité de production. Nous avons développé nos départements usinage et montage mais aussi qualité.

Wir begrüßen Sie in unseren Einrichtungen, wo es einige Änderungen gibt. Madaula investiert in die Verbesserung unserer Fertigungskapazität. Wir erweitern unsere Montage und Qualitätsabteilungen.



Passion for precision

Precise and rigid manufacture
Adaptable to all types of machines
100% Checked and tested
High speed rotation
Longer tool life

All type of tapers and norms available.
Tous types de cônes et des normes disponibles.
Alle Arten von Werkzeugaufnahmen verfügbar.

0-360° Fully adjustable with graduated ring.
Bague graduée entièrement réglable 0-360°.
0-360° einstellbarer Teilungsring.

High precision P4 quality preloaded bearings.
Roulements de haute précision préchargés.
P4 Qualität von hoher Präzision.

Improved sealing design combining a labyrinth and optimized friction seals to get hermetically sealed spindles.
Amélioration de la conception de l'étanchéité en combinant un labyrinthe et joints à friction optimisée pour obtenir une parfaite étanchéité.
Verbesserte Konzeption der Abdichtung, welche durch die Kombination eines Labyrinths mit reibungsoptimierten Dichtungen erreicht wird, um hermetisch abgedichtete Spindeln zu erhalten.

Multiple output options.
Multiples options de sortie.
Viele Möglichkeiten der Werkzeugaufnahme.

Primary labyrinth seal.
Joint à labyrinthe primaire.
Primäre Labyrinthdichtung.

High grade synthetic grease for long life lubrication.
Lubrification à la graisse à longue durée de vie.
Hochwertiges synthetisches Schmierfett für eine Lebensdauerschmierung.

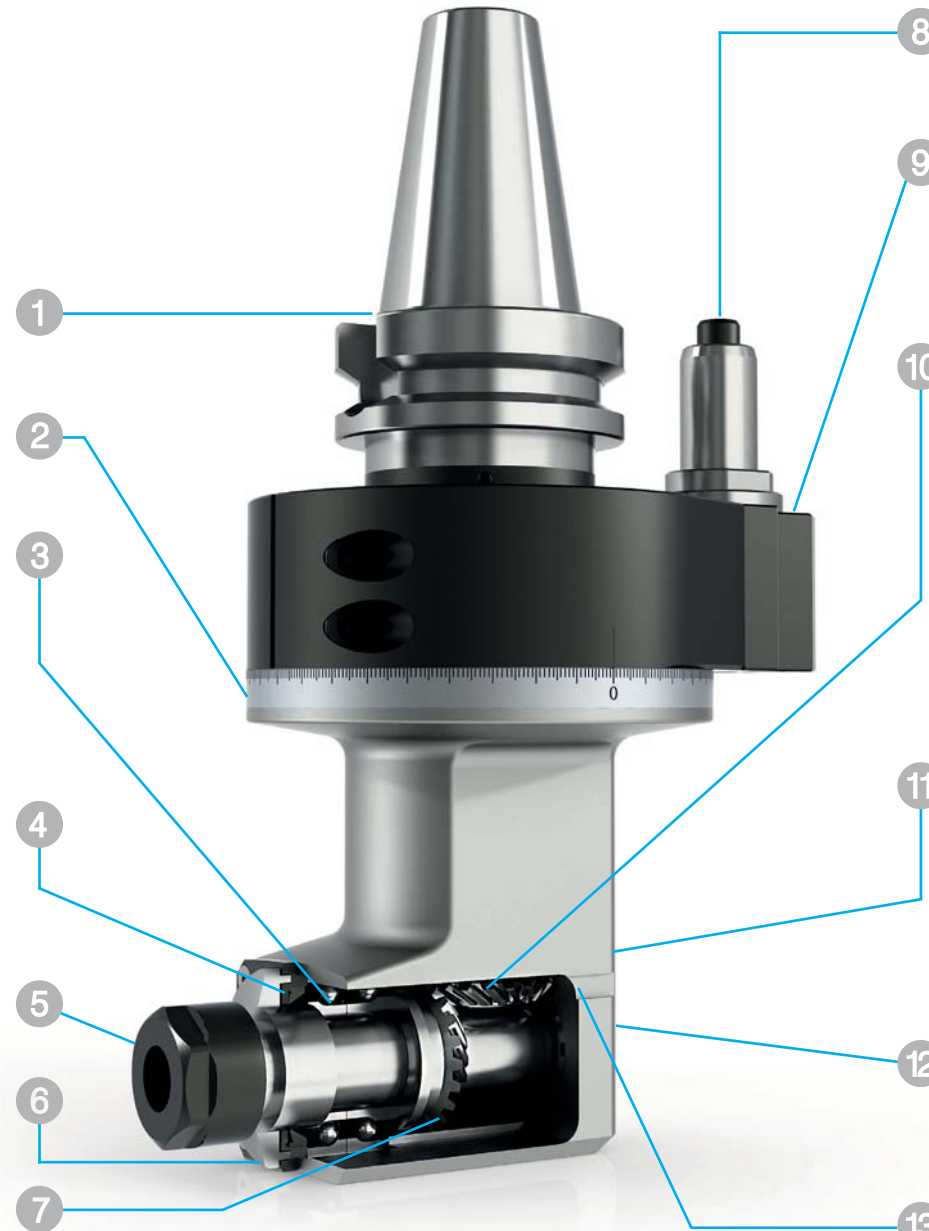

8 Automatic index arm.
Doigt d'indexation automatique.
Automatische Indexierung.

9 Modular group with multiple index arm distance options.
Groupe modulaire avec multiples options de distance du doigt d'indexation.
Baukastensystem mit mehreren Indexierungsabstands-Optionen.

10 Hand matched or ground spiral bevel gears with new tooth geometry and surface treatments to minimize backlash.
Smooth and quiet running with 30-50% higher torque.

Engrenages spiro-coniques rectifiés ou rodés pour un jeu de denture optimal, avec de nouvelles géométries de dents et des traitements de surfaces les plus performants. Fonctionnement souple et silencieux avec un accroissement de 30 à 50 % du couple transmissible.
Spiral Kegelräder mit neuer Zahngeometrie und Oberflächenbehandlungen zur Verminderung des Spiels.
Glatter und leiser Lauf mit 30-50% höherem Drehmoment.

11 Hardened aluminium bodies for light heads
Steel bodies for heavy heads
Bodies machined from a solid block.
Corps en aluminium durci pour les têtes légères
Corps en acier pour les têtes lourdes
Corps usinés du massif.
Gehärtete Aluminium-Gehäuse für leichte Köpfe
Stahlgehäuse für schwere Köpfe
Gehäuse bearbeitet aus einem Block.

12 Also available with coolant through the spindle.
Disponible avec passage du liquide de refroidissement à travers de la broche.
Axiale Kühlmittelzufuhr möglich.

13 Flat surface for an easy alignment.
Surface pour un alignement facile.
Passfläche für eine einfache Ausrichtung.

The best solution for a perfect application

CA SERIES 90° Angle heads

For drilling, tapping, milling. Add one axis to your machine.

Pour le perçage, taraudage, fraisage. Ajoutent un axe supplémentaire à votre machine.

Zum Bohren, Gewindeschneiden, Fräsen. Fügen Sie Ihrer Maschine eine Achse hinzu.



CAR SERIES 0-90° Adjustable angle heads

For drilling, tapping, milling ops. at any angle.

Pour le perçage, taraudage, fraisage et opérations à n'importe quel angle.

Zum Bohren, Gewindeschneiden, Fräsen in beliebigem Winkel.



CAF - CAFS SERIES 0-90° Fixed angle heads

For drilling, tapping, milling ops. at any angle with increased rigidity.

Pour le perçage, taraudage, fraisage et opérations à n'importe quel angle avec une rigidité accrue.

Zum Bohren, Gewindeschneiden, Fräsen in festen Winkel mit erhöhter Steifigkeit.



CAP SERIES Slim design

To work inside small holes or narrow spaces.

Pour travailler à l'intérieur de petits alésages ou des espaces étroits.

Geeignet für die Bearbeitung innerhalb kleiner Bohrungen oder schmaler Räume.



CAD SERIES 90° Double output

For operations in both directions.

Pour les opérations sur les deux directions.

Geeignet für die Bearbeitung in beide Richtungen.



EXTENDED CA 90° Angle heads for long pieces

Optional flange mounting for improved rigidity.

Bride de fixation en option pour une meilleure rigidité.

Geeignet für die Bearbeitung in beide Richtungen.



Application fields

Aerospace

Aéronautique / Luft-und Raumfahrt

Automotive

Automobile / Automobilindustrie

Components

Composants mécaniques / Bauelemente

Electronics

Electronique / Elektronik

Energy

Énergie / Energieindustrie

Heavy industry

Industrie lourde / Schwerindustrie

Machine tool equipment

Équipement de machine-outils /
Ausrüstung für Werkzeugmaschinen

Medical

Médical / Gesundheitsindustrie

Micro-mechanics

Micro-mécanique / Micro-Mechanik

Defense

Défense / Verteidigung

Orthopaedics

Orthopédie / Orthopädie

Power generation

Génération d'énergie / Stromerzeugung

Railway engineering

Ferroviaire / Bahntechnik

Watch-making industry

Industrie horlogère / Uhrenindustrie

Wind industry

Industrie éolienne / Windindustrie





Turbine image by Kollected

CA **OC** 90°
Angle head

MADAULA
creative solutions

Technical Data

Caractéristiques techniques / Technische Daten

	ER-11 / 7 mm
R.P.M max	4.000
	3.5 kg
	1:1
KW	1 kW
Nm max	4 Nm
Rotation	in = out

L / H

Other measures under request

Autres mesures sur demande

Weitere Maßnahmen auf Anfrage

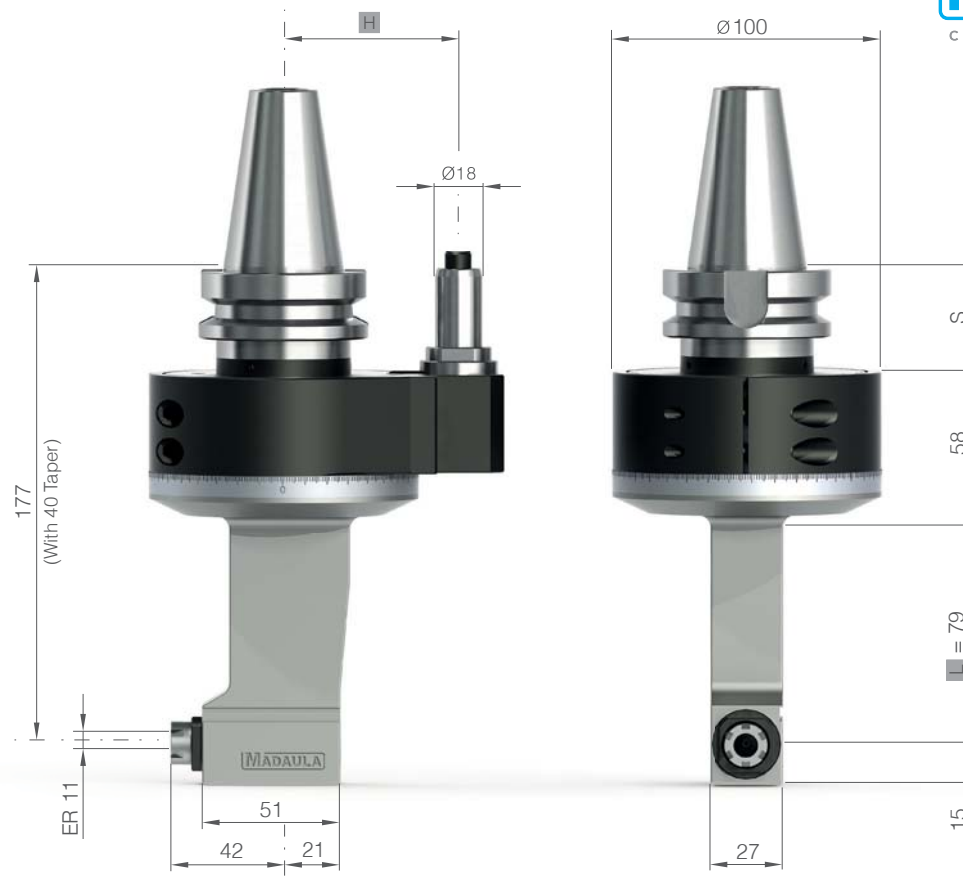
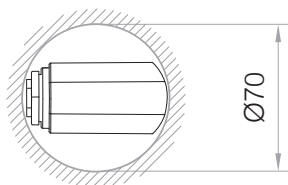

Taper Cône / Kegel	Size Taille / Größe	H	S
DIN 69871 / 2080	30/40/50	55/65/80	40
CAT	30/40/50	55/65/80	40
MAS-BT	30/40/50	55/65/80	40/40/50
HSK	50/63/100	55/65/80	40/40/50
CAPTO	C5/C6/C8	55/65/80	40/40/50
KM	50/63/100	55/65/80	40/40/50

Standard Equipment

Standard / Standard

Optional Equipment

Optionel / Option

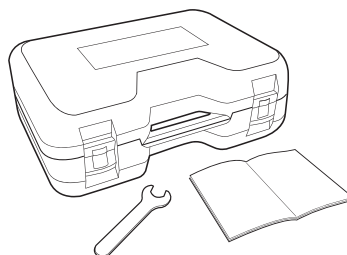

Stop Block

Bloc d'arrêt / Anschlag-Block

See page 55 

Collets

Pinces / Spannzangen

See page 56 

Coolant through index pin

Arrosage par le doigt d'indexage / Kühlmittelzufuhr durch bolzen

bar/psi max 12/175

High speed option RPM max

Haute vitesse en option RPM / Hochgeschwindigkeit optional UPM max

6.000

CA OE 90° Angle head

Technical Data

Caractéristiques techniques / Technische Daten

	ER-16A / 10 mm
R.P.M max	4.000
 KG	3.5 kg
	1:1
KW	2 kW
Nm max	6 Nm
Rotation	in = out

L / H

Other measures under request

Autres mesures sur demande

Weitere Maßnahmen auf Anfrage

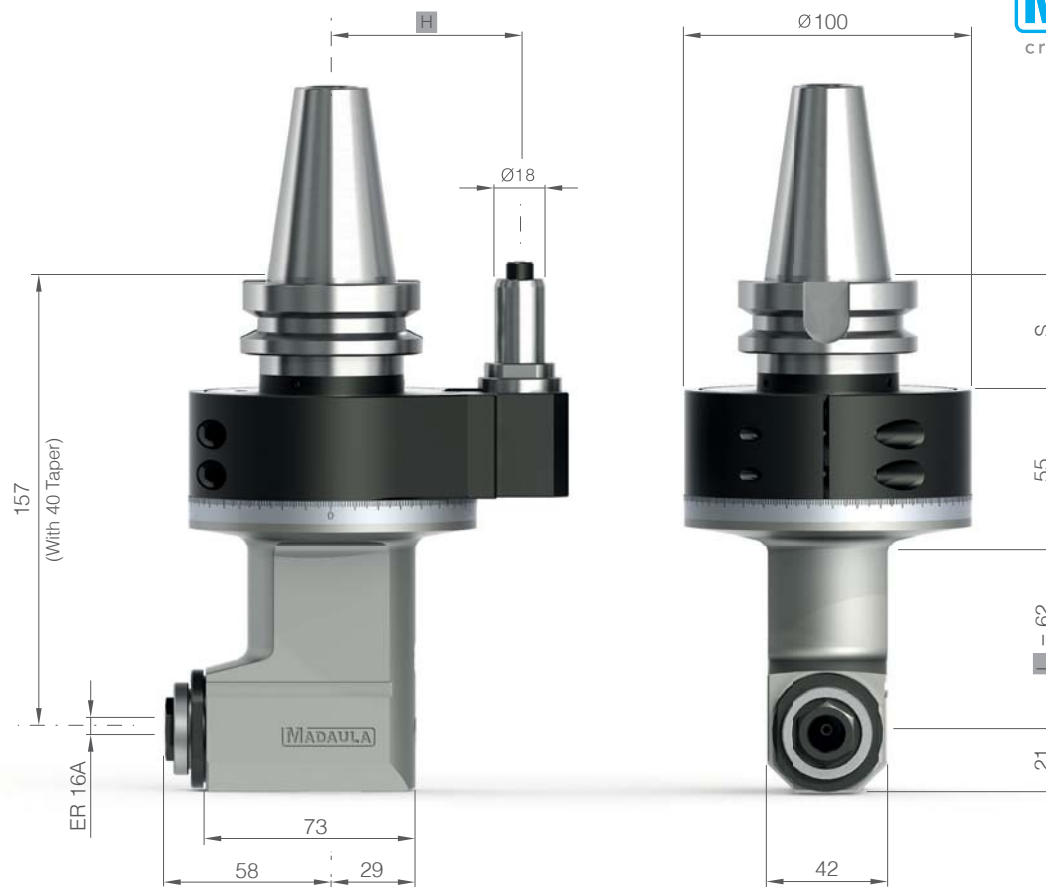
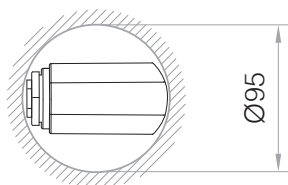

MADAULA
creative solutions

Taper Cône / Kegel	Size Taille / Größe	H	S
DIN 69871 / 2080	30/40/50	55/65/80	40
CAT	30/40/50	55/65/80	40
MAS-BT	30/40/50	55/65/80	40/40/50
HSK	50/63/100	55/65/80	40/40/50
CAPTO	C5/C6/C8	55/65/80	40/40/50
KM	50/63/100	55/65/80	40/40/50

Standard Equipment

Standard / Standard

Optional Equipment

Optionel / Option

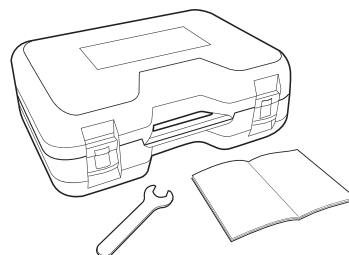

Stop Block

Bloc d'arrêt / Anschlag-Block

See page 55 

Collets

Pinces / Spannzangen

See page 56 

Coolant through index pin

Arrosage par le doigt d'indexage / Kühlmittelzufuhr durch bolzen

bar/psi max 12/175

High speed option RPM max

Haute vitesse en option RPM / Hochgeschwindigkeit optional UPM max

10.000

CA



90°
Angle head

Technical Data

Caractéristiques techniques / Technische Daten

	ER-25A / 16 mm
R.P.M max	6.000
	4.8 kg
	1:1
KW	3.5 kW
Nm max	14 Nm
Rotation	in = out

L / H

Other measures under request

Autres mesures sur demande

Weitere Maßnahmen auf Anfrage

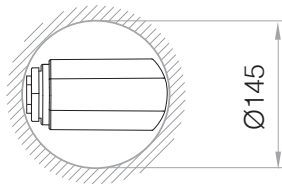

Taper Cône / Kegel	Size Taille / Größe	H	S
-----------------------	------------------------	---	---

DIN 69871 / 2080	30/40/50	55/65/80	40
CAT	30/40/50	55/65/80	40
MAS-BT	30/40/50	55/65/80	40/40/50
HSK	50/63/100	55/65/80	40/40/50
CAPTO	C5/C6/C8	55/65/80	40/40/50
KM	50/63/100	55/65/80	40/40/50

Standard Equipment

Standard / Standard

Optional Equipment

Optionel / Option

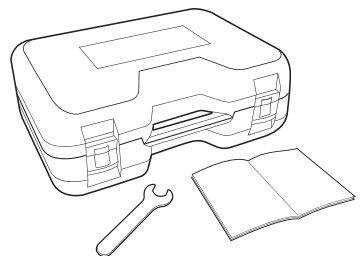

Stop Block

Bloc d'arrêt / Anschlag-Block

See page 55

Collets

Pinces / Spannzangen

See page 56

Coolant through index pin

Arrosage par le doigt d'indexage / Kühlmittelzufuhr durch bolzen

bar/psi max 12/175

High speed option RPM max

Haute vitesse en option RPM / Hochgeschwindigkeit optional UPM max

8.000

CA 1

90° Angle head

Technical Data

Caractéristiques techniques / Technische Daten

	ER-32 / 20 mm
R.P.M max	Heavy duty bearings 3.000
	7.5 kg
	1:1
KW	7 kW
Nm max	35 Nm
Rotation	in = out

L / H

Other measures under request

Autres mesures sur demande

Weitere Maßnahmen auf Anfrage

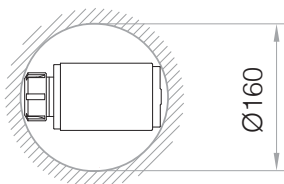

MADAULA

creative solutions

Taper Cône / Kegel	Size Taille / Größe	H	S
DIN 69871 / 2080	40/50	65/80	40
CAT	40/50	65/80	40
MAS-BT	40/50	65/80	40/50
HSK	63/100	65/80	40/50
CAPTO	C6/C8	65/80	40/50
KM	63/100	65/80	40/50

Standard Equipment

Standard / Standard

Optional Equipment

Optionel / Option

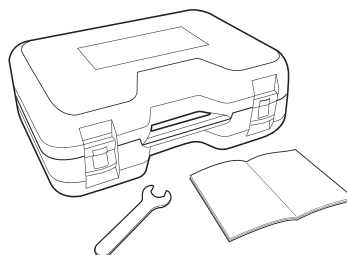

Stop Block

Bloc d'arrêt / Anschlag-Block

See page 55 

Collets

Pinces / Spannzangen

See page 56 

Coolant through index pin

Arrosage par le doigt d'indexage / Kühlmittelzufuhr durch bolzen

bar/psi max 12/175

High speed option RPM max

Haute vitesse en option RPM / Hochgeschwindigkeit optional UPM max



6.000

CA 1

90° Angle head

Technical Data

Caractéristiques techniques / Technische Daten

		ISO-30 / DIN-2079
R.P.M max	Heavy duty bearings	3.000
		7.5 kg
		1:1
KW		7 kW
Nm max		35 Nm
Rotation		in = out

L / H

Other measures under request

Autres mesures sur demande

Weitere Maßnahmen auf Anfrage

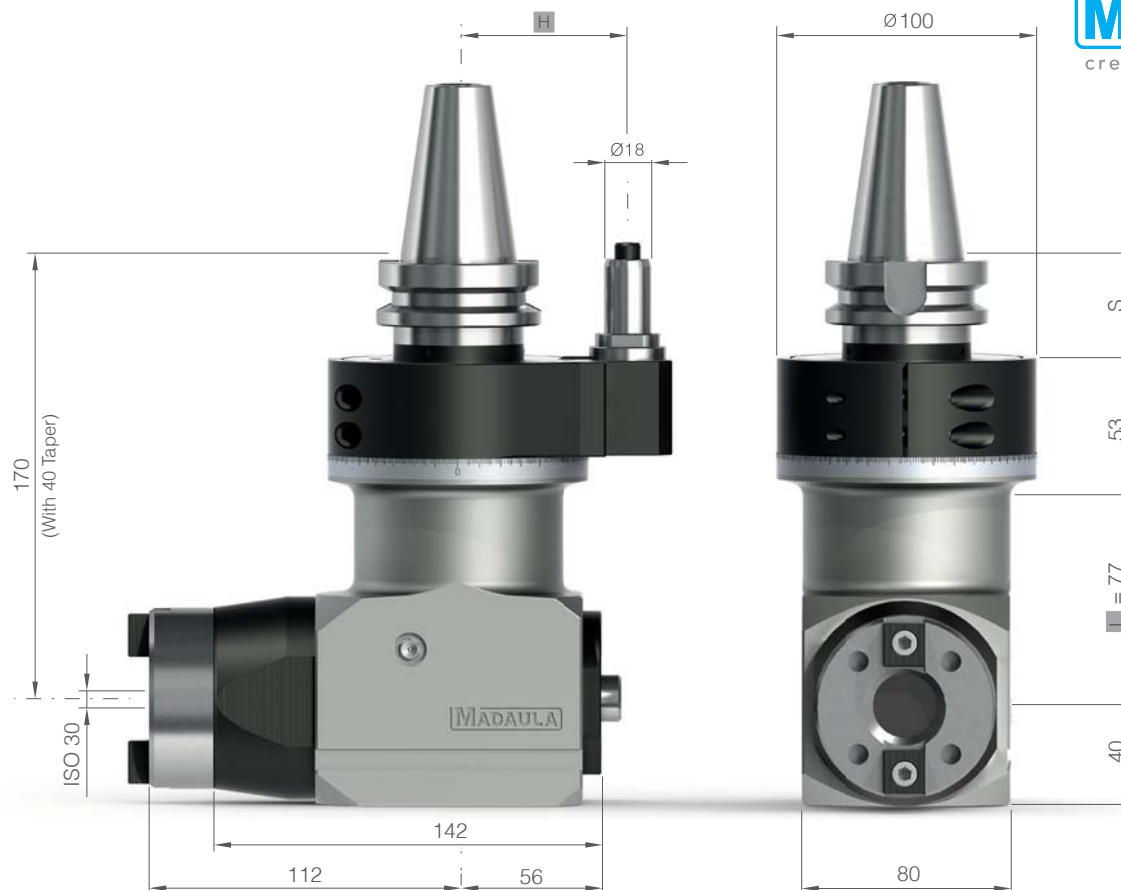
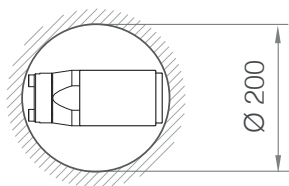

MADAULA

creative solutions

Taper Cône / Kegel	Size Taille / Größe	H	S
DIN 69871 / 2080	40/50	65/80	40
CAT	40/50	65/80	40
MAS-BT	40/50	65/80	40/50
HSK	63/100	65/80	40/50
CAPTO	C6/C8	65/80	40/50
KM	63/100	65/80	40/50

Standard Equipment

Standard / Standard

Optional Equipment

Optionel / Option

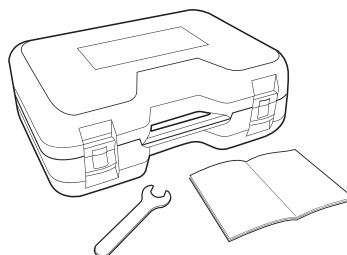

Stop Block

Bloc d'arrêt / Anschlag-Block

See page 55 

Collets

Pinces / Spannzangen

See page 56 

Coolant through index pin

Arrosage par le doigt d'indexage / Kühlmittelzufuhr durch bolzen

bar/psi max 12/175

High speed option RPM max

Haute vitesse en option RPM / Hochgeschwindigkeit optional UPM max

6.000



CA 2

90°
Angle head

MADAULA
creative solutions

Technical Data

Caractéristiques techniques / Technische Daten

		ER-40 / 26 mm
R.P.M max	Heavy duty bearings	2.500
		14 kg
		1:1
KW		16 kW
Nm max		90 Nm
Rotation		in = out

L / H

Other measures under request

Autres mesures sur demande

Weitere Maßnahmen auf Anfrage

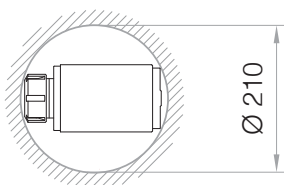

Taper Cône / Kegel	Size Taille / Größe	H	S
DIN 69871 / 2080	50	80	40
CAT	50	80	40
MAS-BT	50	80	50
HSK	80/100	80	40/50
CAPTO	C8	80	50
KM	80/100	80	40/50

Standard Equipment

Standard / Standard

Optional Equipment

Optionel / Option

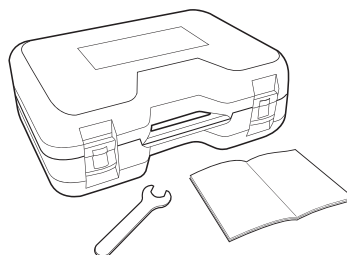

Stop Block

Bloc d'arrêt / Anschlag-Block

See page 55 

Collets

Pinces / Spannzangen

See page 56 

Coolant through index pin

Arrosage par le doigt d'indexage / Kühlmittelzufuhr durch bolzen

bar/psi max 12/175

High speed option RPM max

Haute vitesse en option RPM / Hochgeschwindigkeit optional UPM max



6.000

CA 2

90° Angle head

Technical Data

Caractéristiques techniques / Technische Daten

	ISO-30 / DIN-2079
R.P.M max	Heavy duty bearings 2.500
	14 kg
	1:1
KW	16 kW
Nm max	90 Nm
Rotation	in = out

L / H

Other measures under request

Autres mesures sur demande

Weitere Maßnahmen auf Anfrage

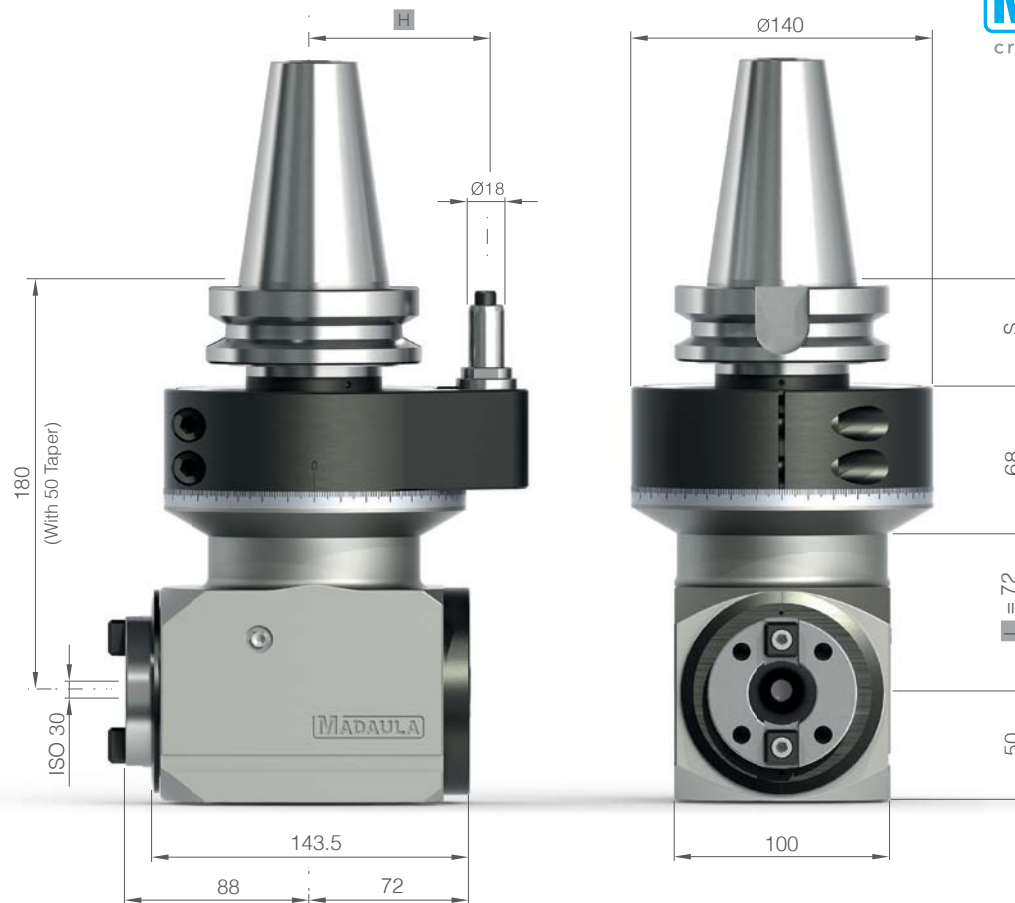
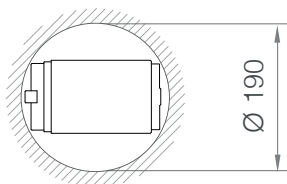

MADAULA

creative solutions

Taper Cône / Kegel	Size Taille / Größe	H	S
DIN 69871 / 2080	50	80	40
CAT	50	80	40
MAS-BT	50	80	50
HSK	80/100	80	40/50
CAPTO	C8	80	50
KM	80/100	80	40/50

Standard Equipment

Standard / Standard

Optional Equipment

Optionel / Option

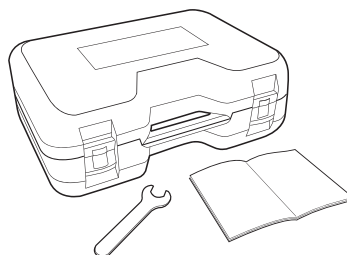

Stop Block

Bloc d'arrêt / Anschlag-Block

See page 55 

Collets

Pinces / Spannzangen

See page 56 

Coolant through index pin

Arrosage par le doigt d'indexage / Kühlmittelzufuhr durch bolzen

bar/psi max 12/175

High speed option RPM max

Haute vitesse en option RPM / Hochgeschwindigkeit optional UPM max

6.000



90°
Angle head

Technical Data

Caractéristiques techniques / Technische Daten

	ISO-40 / DIN-2079
R.P.M max	Heavy duty bearings 2.000
	20 kg
	1:1
KW	20 kW
Nm max	130 Nm
Rotation	in = out

L / H

Other measures under request

Autres mesures sur demande

Weitere Maßnahmen auf Anfrage

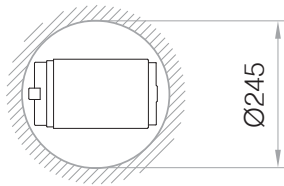

MADAULA
creative solutions

Taper Cône / Kegel	Size Taille / Größe	H	S
-----------------------	------------------------	---	---

DIN 69871 / 2080	50	80	40
CAT	50	80	40
MAS-BT	50	80	50
HSK	80/100	80	40/50
CAPTO	C8	80	50
KM	80/100	80	40/50

Standard Equipment

Standard / Standard

Optional Equipment

Optionel / Option

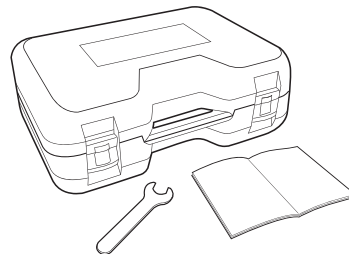

Stop Block

Bloc d'arrêt / Anschlag-Block

See page 55

Collets

Pinces / Spannzangen

See page 56

Coolant through index pin

Arrosage par le doigt d'indexage / Kühlmittelzufuhr durch bolzen

bar/psi max 12/175

High speed option RPM max

Haute vitesse en option RPM / Hochgeschwindigkeit optional UPM max

4.000



90°
Angle head

Technical Data

Caractéristiques techniques / Technische Daten

	ER-50 / 34 mm
R.P.M max	Heavy duty bearings 2.000
	20 kg
	1:1
KW	20 kW
Nm max	130 Nm
Rotation	in = out

L / H

Other measures under request

Autres mesures sur demande

Weitere Maßnahmen auf Anfrage

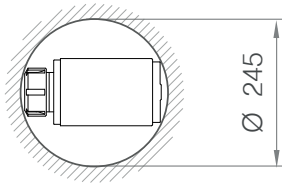

MADAULA
creative solutions

Taper	Size	H	S
-------	------	---	---

DIN 69871 / 2080	50	80	40
CAT	50	80	40
MAS-BT	50	80	50
HSK	80/100	80	40/50
CAPTO	C8	80	50
KM	80/100	80	40/50

Standard Equipment

Standard / Standard

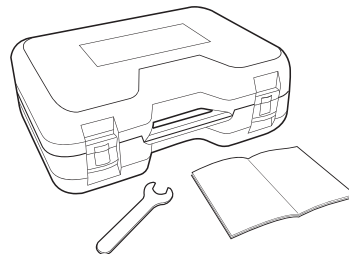

Optional Equipment

Optionel / Option

Stop Block

Bloc d'arrêt / Anschlag-Block

See page 55

Collets

Pinces / Spannzangen

See page 56

Coolant through index pin

Arrosage par le doigt d'indexage / Kühlmittelzufuhr durch bolzen

bar/psi max 12/175

High speed option RPM max

Haute vitesse en option RPM / Hochgeschwindigkeit optional UPM max

4.000



CA

3E EXTENDED

90° Angle head

Technical Data

Caractéristiques techniques / Technische Daten

		ISO-40 / DIN-2079
R.P.M max	Heavy duty bearings	2.000
		36 kg
		1:1
KW		20 kW
Nm max		130 Nm
Rotation		in = out

L

Other measures under request

Autres mesures sur demande

Weitere Maßnahmen auf Anfrage

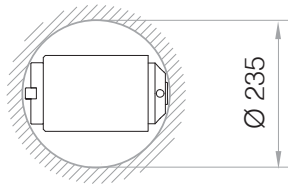

MADAULA
creative solutions

Flange mounted giving an increased rigidity.

Rigidité accrue lors du montage par flasque sur la machine.

Erhöhte Starrheit durch Flanscheinbau direkt an die Maschine.

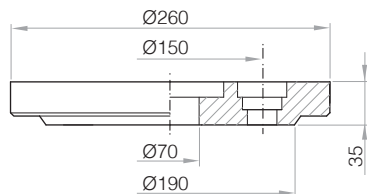

Standard Equipment

Standard / Standard

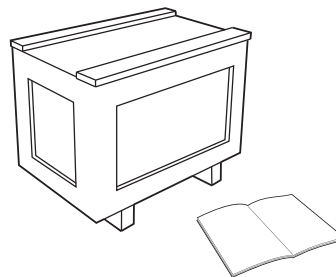

Optional Equipment

Optionel / Option

Internal air pressure

Suppression d'air interne / Sperrluft

bar/psi max 0.3/4

Quick change system

Système de changement rapide / Schnellwechselaufnahme

Alternative outputs

Sortie alternative / Alternative ausgänge

See page 55



High speed option RPM max

Haute vitesse en option RPM / Hochgeschwindigkeit optional UPM max

4.000



CA 4

90° Angle head

MADAULA
creative solutions

Technical Data

Caractéristiques techniques / Technische Daten

	ISO-50 / DIN-2079
R.P.M max	Heavy duty bearings 2.000
	82 kg
	1:1
KW	40 kW
Nm max	280 Nm
Rotation	in = out

Other measures under request

Autres mesures sur demande

Weitere Maßnahmen auf Anfrage

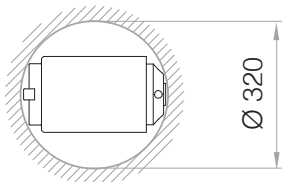

Flange mounted giving an increased rigidity.

Rigidité accrue lors du montage par flasque sur la machine.

Erhöhte Starrheit durch Flanscheinbau direkt an die Maschine.



Standard Equipment

Standard / Standard

Optional Equipment

Optionel / Option

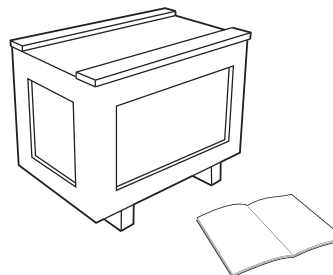

Internal air pressure

Suppression d'air interne / Sperrluft

bar/psi max 0.3/4

Quick change system

Système de changement rapide / Schnellwechselaufnahme

Alternative outputs

Sortie alternative / Alternative ausgänge

See page 55





High speed option RPM max

Haute vitesse en option RPM / Hochgeschwindigkeit optional UPM max

3.000

Technical Data

Caractéristiques techniques / Technische Daten

	ER-25A / 16 mm
R.P.M max	6.000
	5 kg
	1:1
KW	3.5 kW
Nm max	14 Nm
Rotation	in = out
Coolant max pressure	12 bar / 175 psi

L / H

Other measures under request

Autres mesures sur demande

Weitere Maßnahmen auf Anfrage

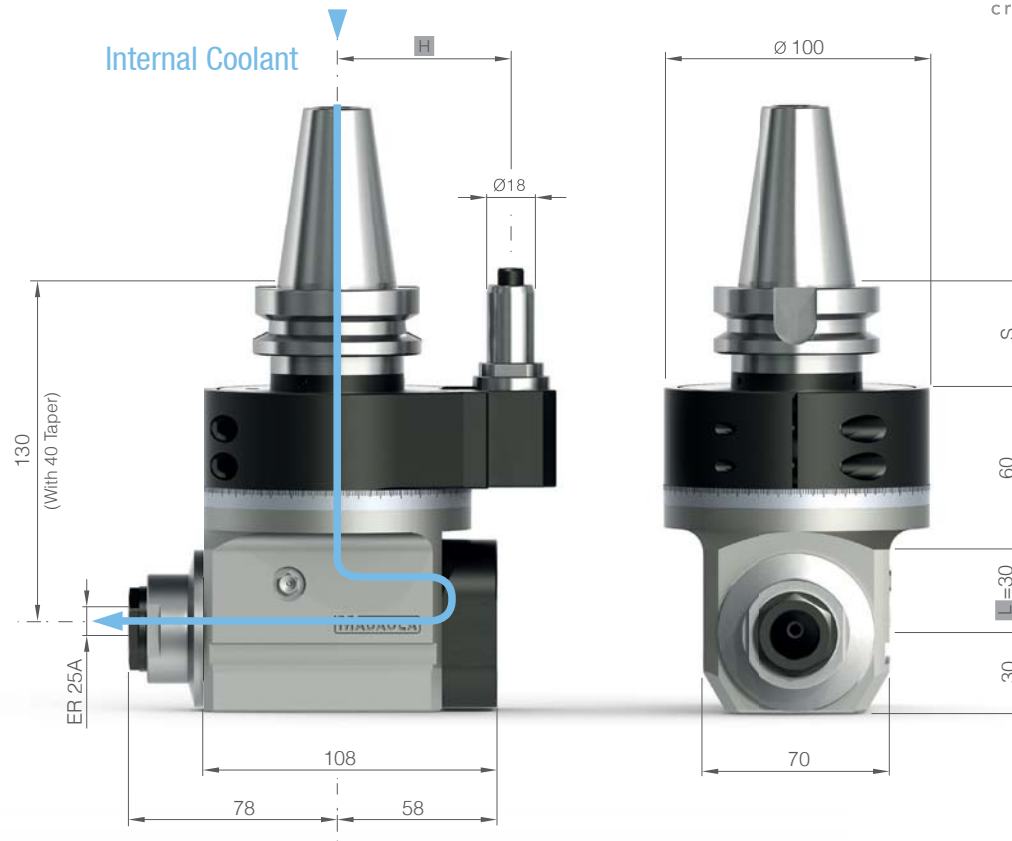
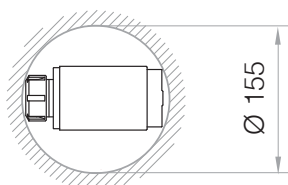

Taper Cône / Kegel	Size Taille / Größe	H	S
DIN 69871 / 2080	30/40/50	55/65/80	40
CAT	30/40/50	55/65/80	40
MAS-BT	30/40/50	55/65/80	40/40/50
HSK	50/63/100	55/65/80	40/40/50
CAPTO	C5/C6/C8	55/65/80	40/40/50
KM	50/63/100	55/65/80	40/40/50

Standard Equipment

Standard / Standard

Optional Equipment

Optionel / Option

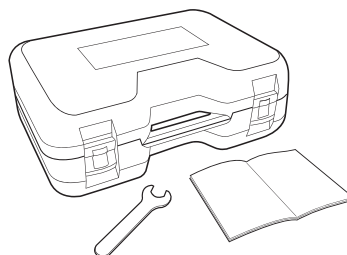

Stop Block

Bloc d'arrêt / Anschlag-Block

See page 55 

Collets

Pinces / Spannzangen

See page 56 

Alternative outputs

Sortie alternative / Alternative ausgänge

See page 55 

High speed option RPM max

Haute vitesse en option RPM / Hochgeschwindigkeit optional UPM max



8.000

CA 1 IC COOLANT

90° Angle head

Technical Data

Caractéristiques techniques / Technische Daten

		ER-32 / 20 mm
R.P.M max	Heavy duty bearings	3.000
		8 kg
		1:1
KW		7 kW
Nm max		35 Nm
Rotation		in = out
Coolant max pressure		12 bar / 175 psi

L / H

Other measures under request

Autres mesures sur demande

Weitere Maßnahmen auf Anfrage

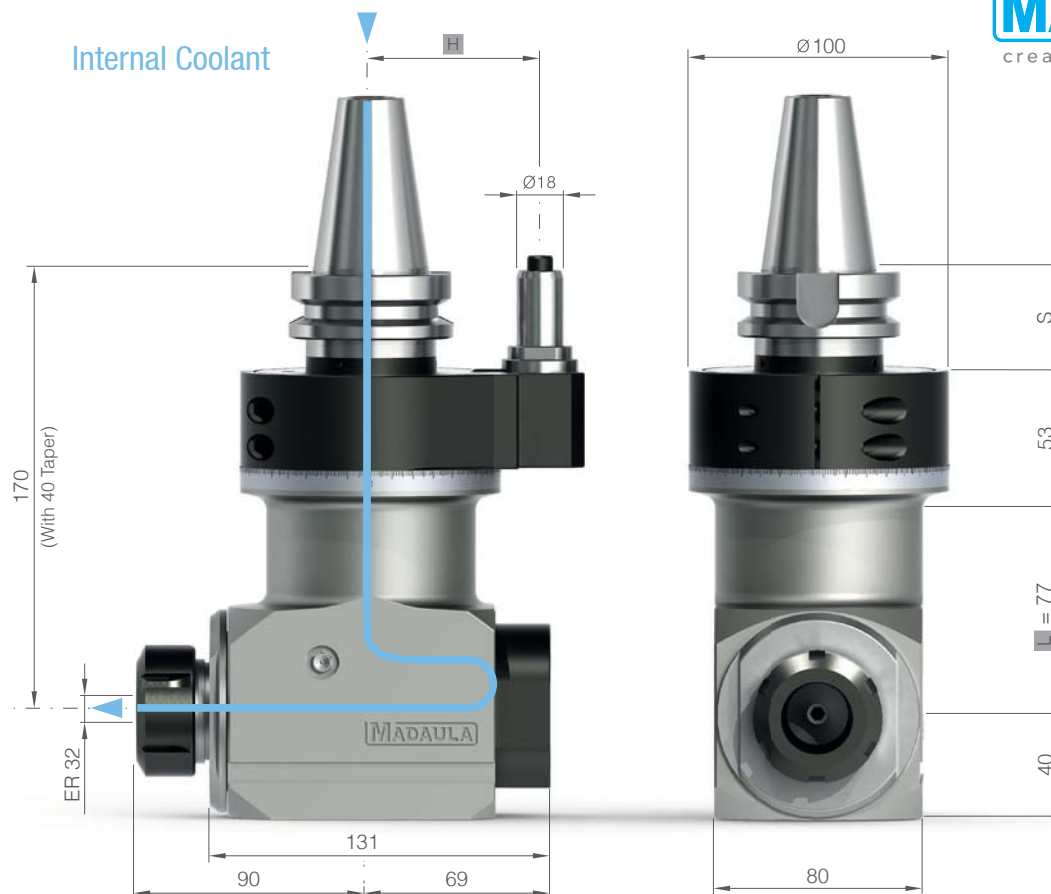
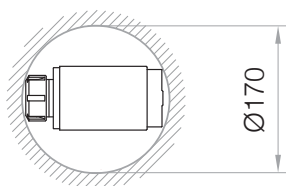

Taper	Size	H	S
Cône / Kegel	Taille / Größe		
DIN 69871 / 2080	40/50	65/80	40
CAT	40/50	65/80	40
MAS-BT	40/50	65/80	40/50
HSK	63/100	65/80	40/50
CAPTO	C6/C8	65/80	40/50
KM	63/100	65/80	40/50

Standard Equipment

Standard / Standard

Optional Equipment

Optionel / Option

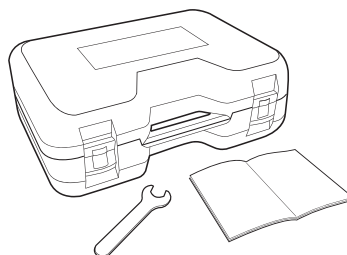

Stop Block

Bloc d'arrêt / Anschlag-Block

See page 55 

Collets

Pinces / Spannzangen

See page 56 

Alternative outputs

Sortie alternative / Alternative ausgänge

See page 55 

High speed option RPM max

Haute vitesse en option RPM / Hochgeschwindigkeit optional UPM max

6.000

Technical Data

Caractéristiques techniques / Technische Daten

		ER-40 / 26 mm
R.P.M max	Heavy duty bearings	2.500
		14 kg
		1:1
KW		16 kW
Nm max		90 Nm
Rotation		in = out
Coolant max pressure		12 bar / 175 psi

L / H

Other measures under request

Autres mesures sur demande

Weitere Maßnahmen auf Anfrage

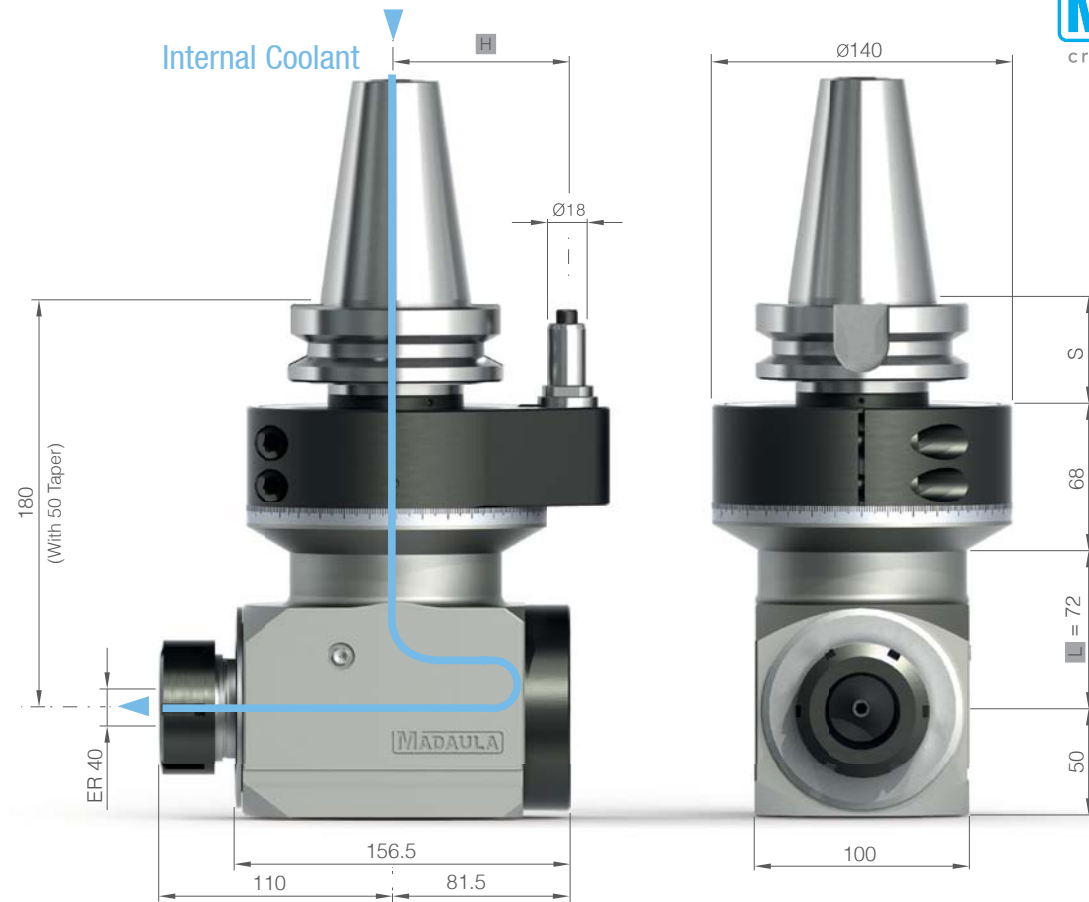
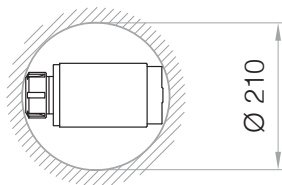

Taper	Size	H	S
Cône / Kegel	Taille / Größe		

DIN 69871 / 2080	50	80	40
CAT	50	80	40
MAS-BT	50	80	50
HSK	80/100	80	40/50
CAPTO	C8	80	50
KM	80/100	80	40/50

Standard Equipment

Standard / Standard

Optional Equipment

Optionel / Option

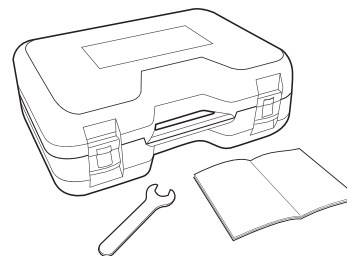

Stop Block

Bloc d'arrêt / Anschlag-Block

See page 55

Collets

Pinces / Spannzangen

See page 56

Alternative outputs

Sortie alternative / Alternative ausgänge

See page 55

High speed option RPM max

Haute vitesse en option RPM / Hochgeschwindigkeit optional UPM max

6.000

Technical Data

Caractéristiques techniques / Technische Daten

	ER-50 / 34 mm
R.P.M max	Heavy duty bearings 2.000
	24.5 kg
	1:1
KW	20 kW
Nm max	130 Nm
Rotation	in = out
Coolant max pressure	12 bar / 175 psi

L / H

Other measures under request

Autres mesures sur demande

Weitere Maßnahmen auf Anfrage

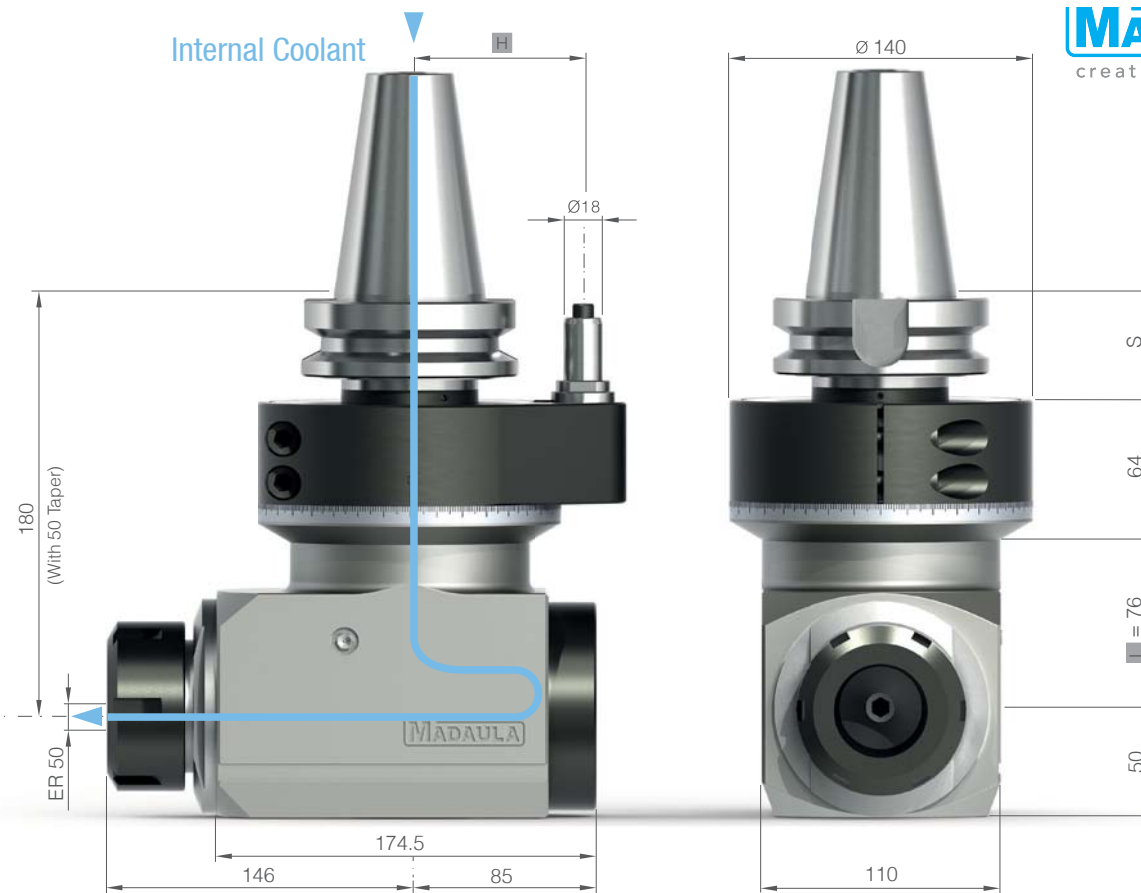
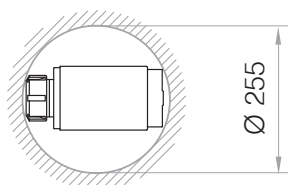

Taper / Cône / Kegel **Size** / Taille / Größe **H** **S**

DIN 69871 / 2080	50	80	40
CAT	50	80	40
MAS-BT	50	80	50
HSK	80/100	80	40/50
CAPTO	C8	80	50
KM	80/100	80	40/50

Standard Equipment

Standard / Standard

Optional Equipment

Optionel / Option

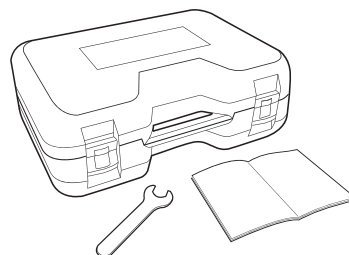

Stop Block

Bloc d'arrêt / Anschlag-Block

See page 55

Collets

Pinces / Spannzangen

See page 56

Alternative outputs

Sortie alternative / Alternative ausgänge

See page 55

High speed option RPM max

Haute vitesse en option RPM / Hochgeschwindigkeit optional UPM max

4.000



CAR

0-90° Adjustable

MADAULA
creative solutions

Technical Data

Caractéristiques techniques / Technische Daten

	ER-16A / 10 mm
R.P.M max	8.000
	4 kg
	1:1
KW	3.5 kW
Nm max	10 Nm
Rotation	in ≠ out

L / H

Other measures under request

Autres mesures sur demande

Weitere Maßnahmen auf Anfrage

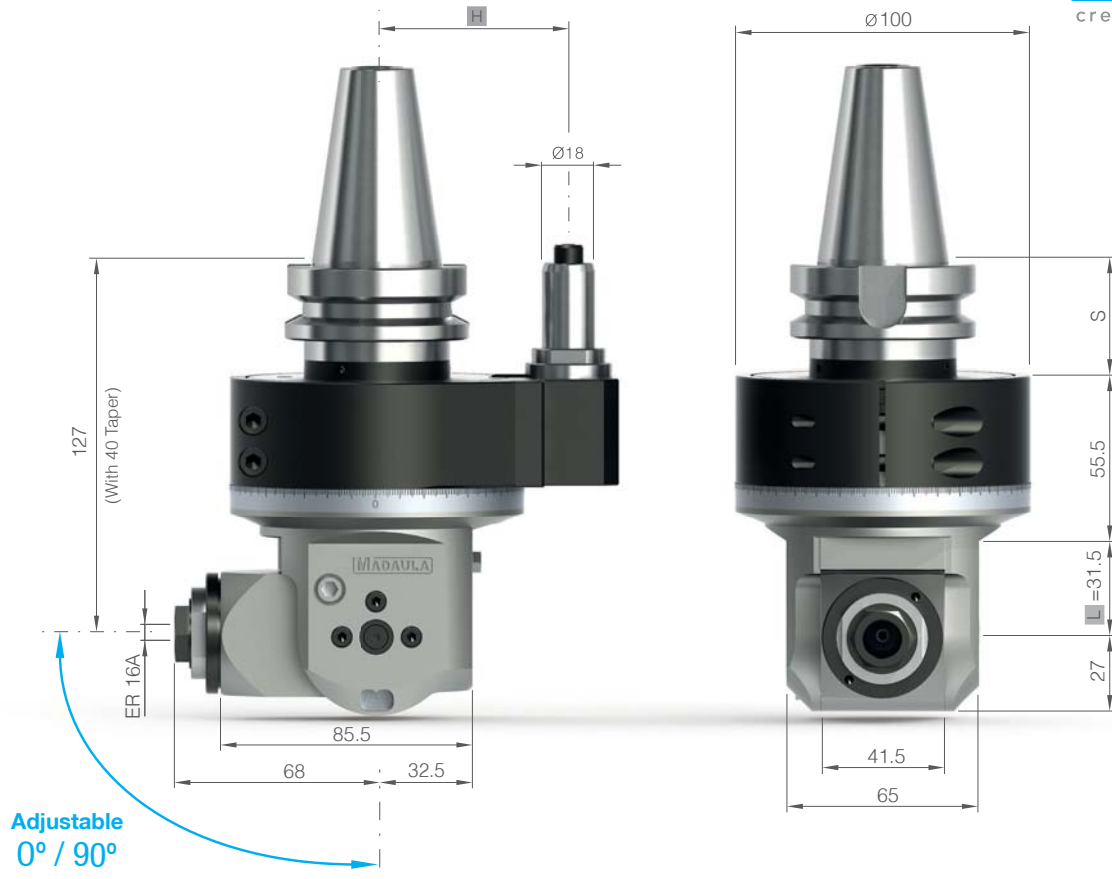
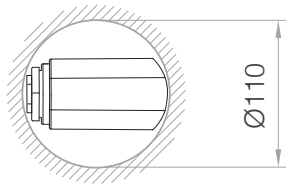

Taper Cône / Kegel	Size Taille / Größe	H	S
-----------------------	------------------------	---	---

DIN 69871 / 2080	30/40/50	55/65/80	40
CAT	30/40/50	55/65/80	40
MAS-BT	30/40/50	55/65/80	40/40/50
HSK	50/63/100	55/65/80	40/40/50
CAPTO	C5/C6/C8	55/65/80	40/40/50
KM	50/63/100	55/65/80	40/40/50

Standard Equipment Standard / Standard

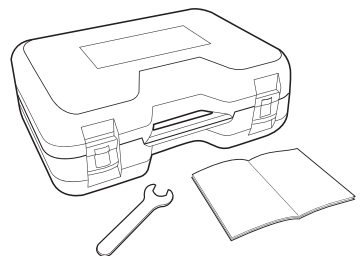

Optional Equipment Optionel / Option

Stop Block
Bloc d'arrêt / Anschlag-Block  See page 55

Collets
Pincés / Spannzangen  See page 56

Coolant through index pin
Arrosage par le doigt d'indexage / Kühlmittelzufuhr durch bolzen **bar/psi max 12/175**

CAR 1

0–90°
Adjustable

Technical Data

Caractéristiques techniques / Technische Daten

	ER-25 / 16 mm
R.P.M max	4.000
	7 kg
	1:1
KW	5 kW
Nm max	12 Nm
Rotation	in ≠ out

L / H

Other measures under request

Autres mesures sur demande

Weitere Maßnahmen auf Anfrage

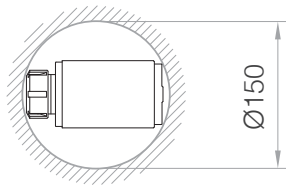

MADAULA
creative solutions

Taper	Size	H	S
Cône / Kegel	Taille / Größe		

DIN 69871 / 2080	40/50	65/80	40
CAT	40/50	65/80	40
MAS-BT	40/50	65/80	40/50
HSK	63/100	65/80	40/50
CAPTO	C6/C8	65/80	40/50
KM	63/100	65/80	40/50

Standard Equipment

Standard / Standard

Optional Equipment

Optionel / Option

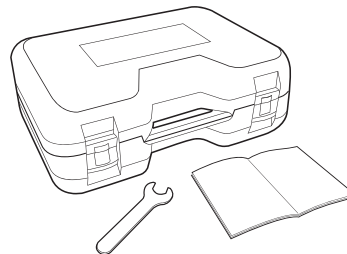

Stop Block

Bloc d'arrêt / Anschlag-Block

See page 55 

Collets

Pinces / Spannzangen

See page 56 

Coolant through index pin

Arrosage par le doigt d'indexage / Kühlmittelzufuhr durch bolzen



bar/psi max 12/175

CAR 1L LIGHT

0-90° Adjustable

Technical Data

Caractéristiques techniques / Technische Daten

	ER-25 / 16 mm
R.P.M max	5.000
	5.5 kg
	1:1
KW	5 kW
Nm max	20 Nm
Rotation	in ≠ out

L / H

Other measures under request

Autres mesures sur demande

Weitere Maßnahmen auf Anfrage

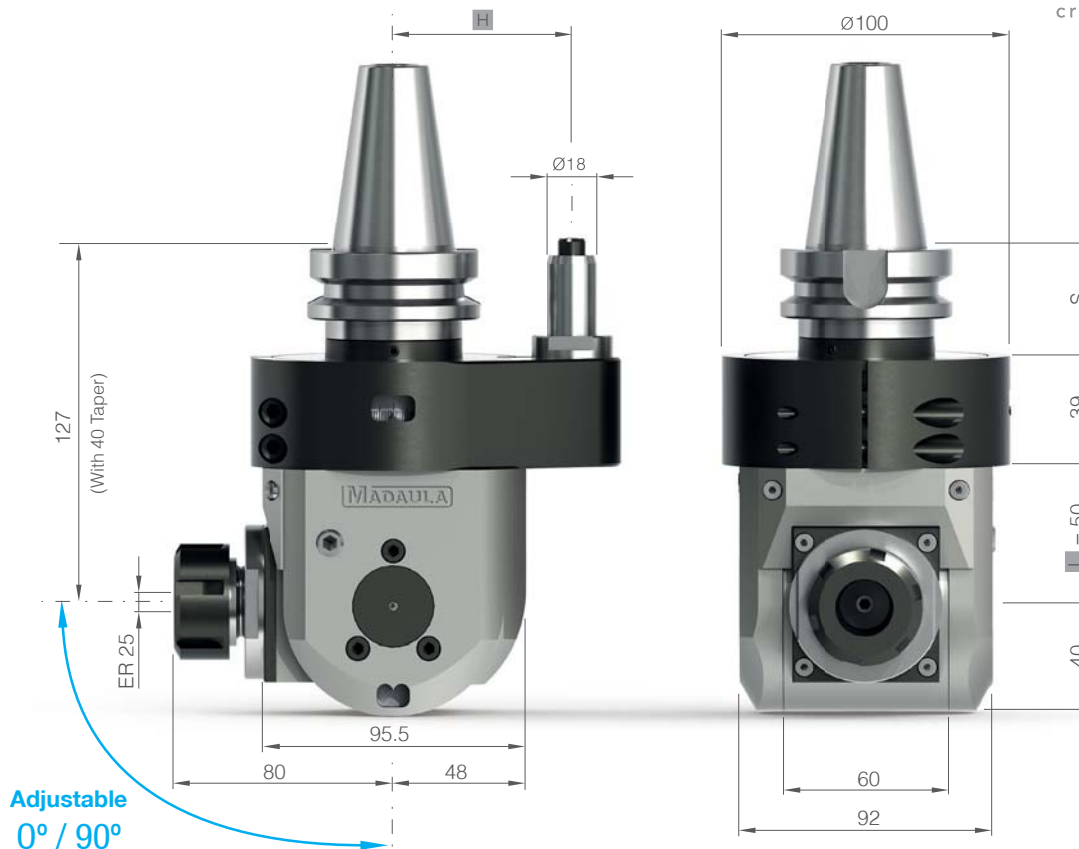
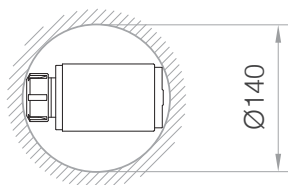

Taper Cône / Kegel	Size Taille / Größe	H	S
DIN 69871 / 2080	40/50	55/65/80	40
CAT	40/50	55/65/80	40
MAS-BT	40/50	55/65/80	40/40/50
HSK	63/100	55/65/80	40/40/50
CAPTO	C6/C8	55/65/80	40/40/50
KM	63/100	55/65/80	40/40/50

Standard Equipment

Standard / Standard

Optional Equipment

Optionel / Option

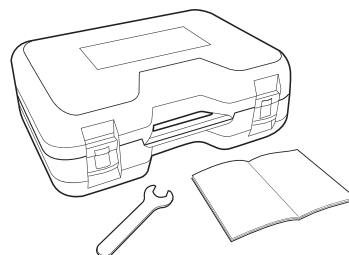

Stop Block

Bloc d'arrêt / Anschlag-Block

See page 55 

Collets

Pinces / Spannzangen

See page 56 

Coolant through index pin

Arrosage par le doigt d'indexage / Kühlmittelzufuhr durch bolzen



bar/psi max 12/175

CAR 2

0-90° Adjustable

Technical Data

Caractéristiques techniques / Technische Daten

		ER-32 / 20 mm
R.P.M max	Heavy duty bearings	4.000
		15.5 kg
		1:1
KW		6 kW
Nm max		22 Nm
Rotation		in ≠ out

L / H

Other measures under request

Autres mesures sur demande

Weitere Maßnahmen auf Anfrage

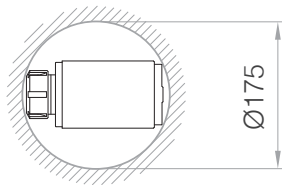

Adjustable
0° / 90°

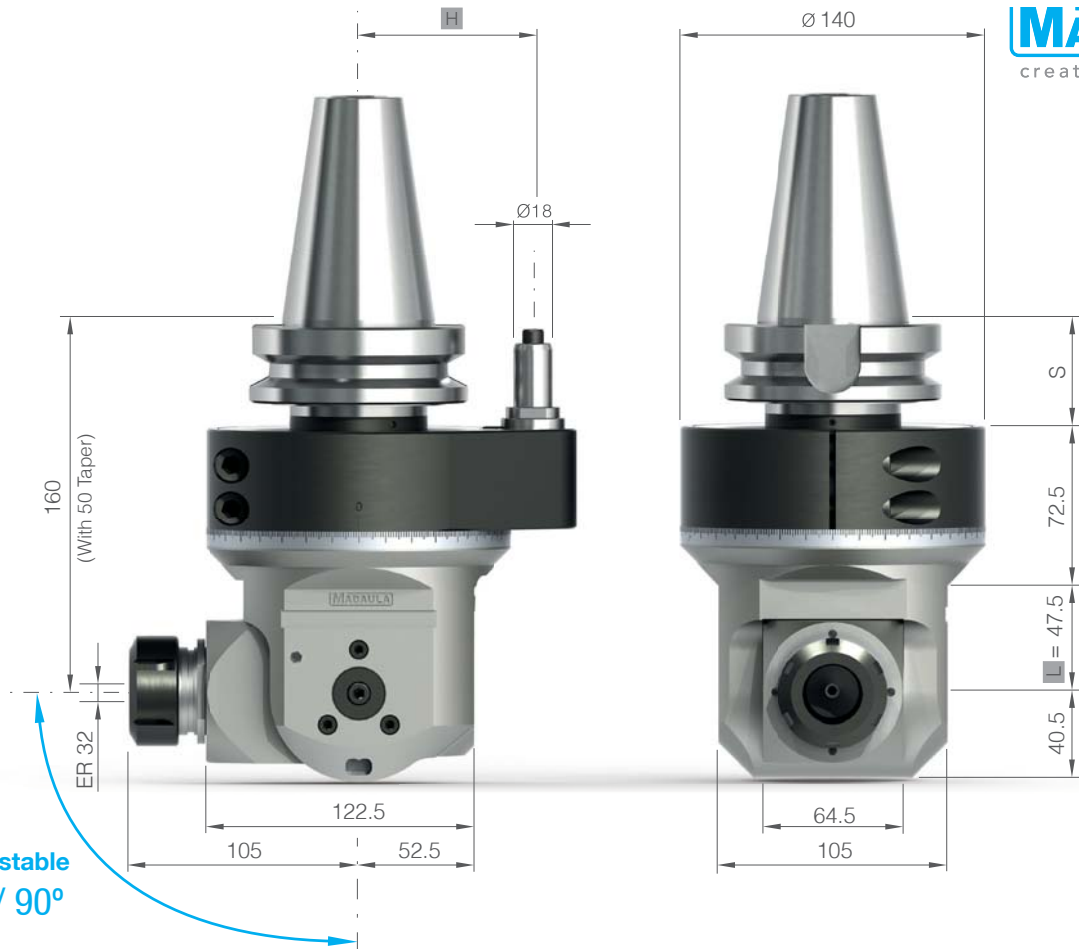

MADAULA
creative solutions

Taper Cône / Kegel	Size Taille / Größe	H	S
-----------------------	------------------------	---	---

DIN 69871 / 2080	50	80	40
CAT	50	80	40
MAS-BT	50	80	50
HSK	80/100	80	40/50
CAPTO	C8	80	50
KM	80/100	80	40/50

Standard Equipment Standard / Standard

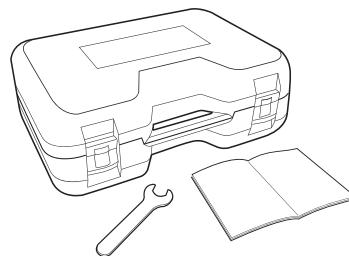

Optional Equipment Optionel / Option

Stop Block
Bloc d'arrêt / Anschlag-Block See page 55 

Collets
Pincés / Spannzangen See page 56 

Coolant through index pin
Arrosage par le doigt d'indexage / Kühlmittelzufuhr durch bolzen bar/psi max 12/175



High speed option RPM max
Haute vitesse en option RPM / Hochgeschwindigkeit optional UPM max 6.000

CAR 3

0-90° Adjustable

Technical Data

Caractéristiques techniques / Technische Daten

		ER-40 / 26 mm
R.P.M max	Heavy duty bearings	3.000
		22 kg
		1:1
KW		10 kW
Nm max		40 Nm
Rotation		in ≠ out

L / H

Other measures under request

Autres mesures sur demande

Weitere Maßnahmen auf Anfrage

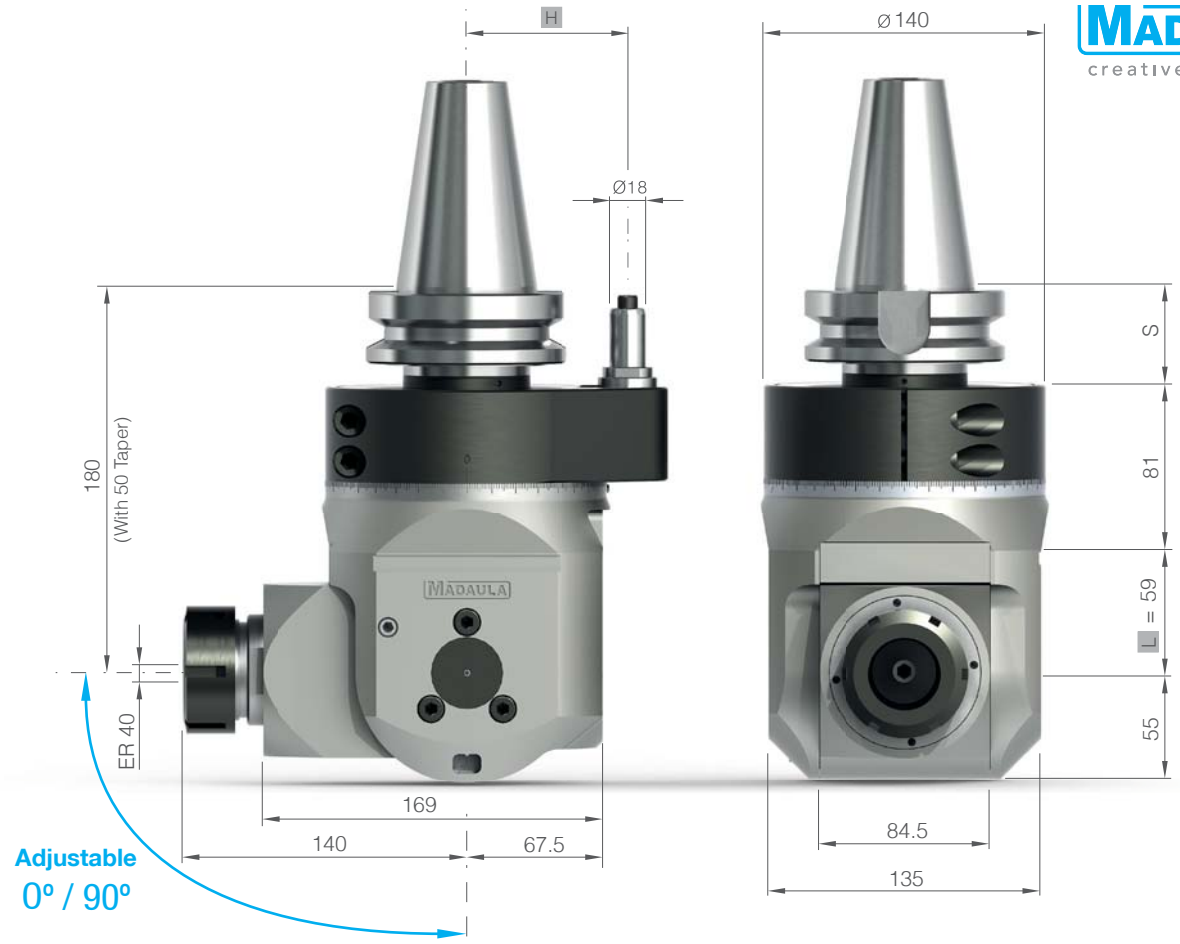
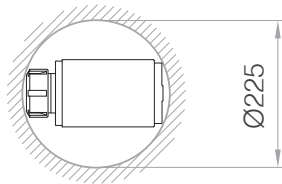

MADAULA

creative solutions

Taper	Size	H	S
Cône / Kegel	Taille / Größe		

DIN 69871 / 2080	50	80	40
CAT	50	80	40
MAS-BT	50	80	50
HSK	80/100	80	40/50
CAPTO	C8	80	50
KM	80/100	80	40/50

Standard Equipment

Standard / Standard

Optional Equipment

Optionel / Option

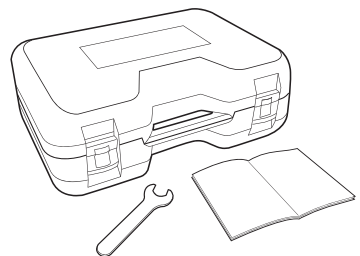

Stop Block

Bloc d'arrêt / Anschlag-Block

See page 55 

Collets

Pinces / Spannzangen

See page 56 

Coolant through index pin

Arrosage par le doigt d'indexage / Kühlmittelzufuhr durch bolzen

bar/psi max 12/175

High speed option RPM max



Haute vitesse en option RPM / Hochgeschwindigkeit optional UPM max

4.000

CAR 4 $\pm 120^\circ$ Adjustable

Technical Data

Caractéristiques techniques / Technische Daten

	ISO-40 / BT-40
R.P.M max	3.500
	64 kg
	1:1
KW	20 kW
Nm max	100 Nm
Rotation	in \neq out

L / H

Other measures under request

Autres mesures sur demande

Weitere Maßnahmen auf Anfrage

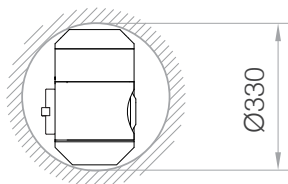

Flange mounted giving an increased rigidity.

Rigidité accrue lors du montage par flasque sur la machine.

Erhöhte Starrheit durch Flanscheinbau direkt an die Maschine.



Standard Equipment

Standard / Standard

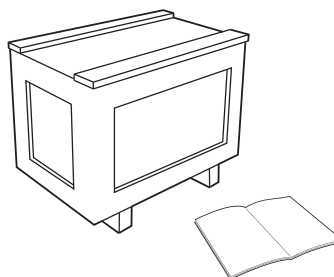

Optional Equipment

Optionel / Option

Internal air pressure

Suppression d'air interne / Sperrluft

bar/psi max 0.3/4

Quick change system

Système de changement rapide / Schnellwechselfaufnahme

Alternative output HSK 63

Sortie alternative HSK 63 / Alternative ausgänge HSK 63

See page 55



X3 Increaser: max speed RPM

X3 Multiplicateur: vitesse max RPM / X3 Übersetzungsverhältnis: höchste Drehzahl UPM **6.000**

CAR 4E EXTENDED Adjustable

Technical Data

Caractéristiques techniques / Technische Daten

	ISO-40 / BT-40
R.P.M max	3.500
	48 kg
	1:1
KW	25 kW
Nm max	95 Nm
Rotation	in = out

L

Other measures under request

Autres mesures sur demande

Weitere Maßnahmen auf Anfrage

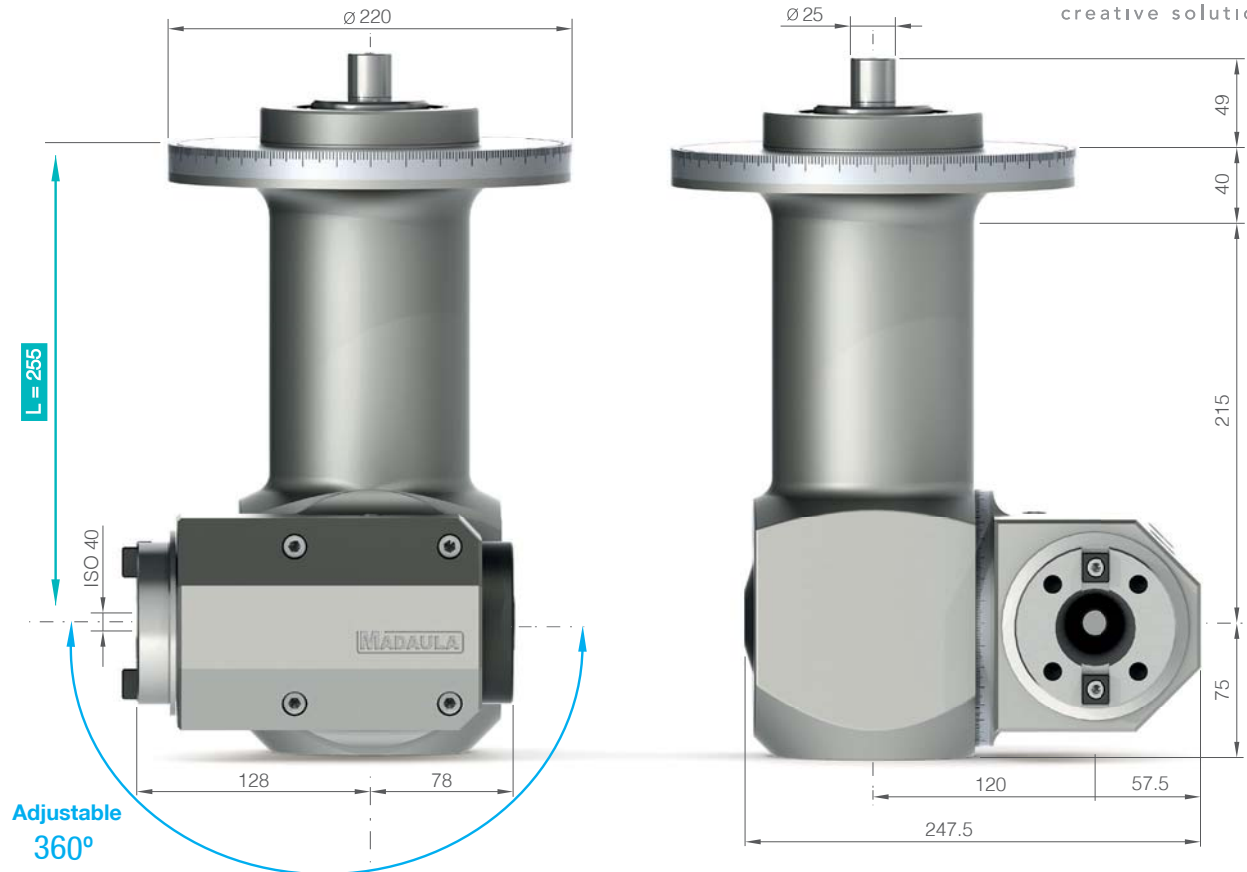
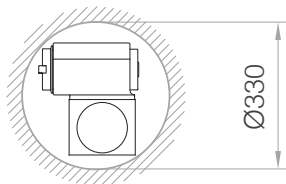

Flange mounted giving an increased rigidity.

Rigidité accrue lors du montage par flasque sur la machine.

Erhöhte Starrheit durch Flanscheinbau direkt an die Maschine.

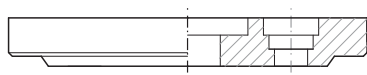

Standard Equipment

Standard / Standard

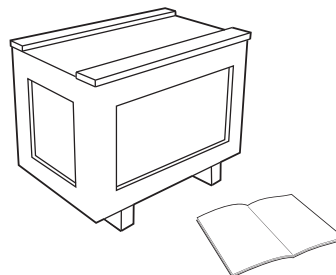

Optional Equipment

Optionel / Option

Internal air pressure

Suppression d'air interne / Sperrluft

bar/psi max 0.3/4

Quick change system

Système de changement rapide / Schnellwechselfaufnahme

Alternative output HSK 63



Sortie alternative HSK 63 / Alternative ausgänge HSK 63

See page 55

CAR 5 $\pm 125^\circ$ Adjustable

Technical Data

Caractéristiques techniques / Technische Daten

	ISO-50 / BT-50
R.P.M max	3.000
	145 kg
	1:1
KW	30 kW
Nm max	375 Nm
Rotation	in \neq out

L / H

Other measures under request

Autres mesures sur demande

Weitere Maßnahmen auf Anfrage

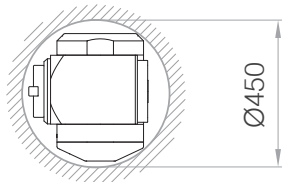

Flange mounted giving an increased rigidity.

Rigidité accrue lors du montage par flasque sur la machine.

Erhöhte Starrheit durch Flanscheinbau direkt an die Maschine.



Standard Equipment

Standard / Standard

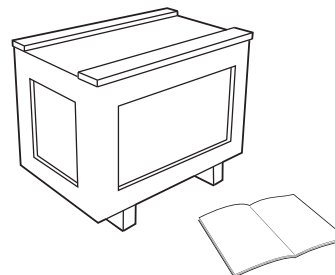

Optional Equipment

Optionel / Option

Internal air pressure

Surpression d'air interne / Sperrluft

bar/psi max 0.3/4

Quick change system

Système de changement rapide / Schnellwechselfaufnahme

Alternative output HSK 63

Sortie alternative HSK 63 / Alternative ausgänge HSK 63

See page 55

Coolant through

Passage du liquide de refroidissement / Innenkühlung

80 bar

Technical Data

Caractéristiques techniques / Technische Daten

	ISO-50 / BT-50
R.P.M max	3.000
	150 kg
	1:1
KW	35 kW
Nm max	500 Nm
Rotation	in = out

L

Other measures under request

Autres mesures sur demande

Weitere Maßnahmen auf Anfrage

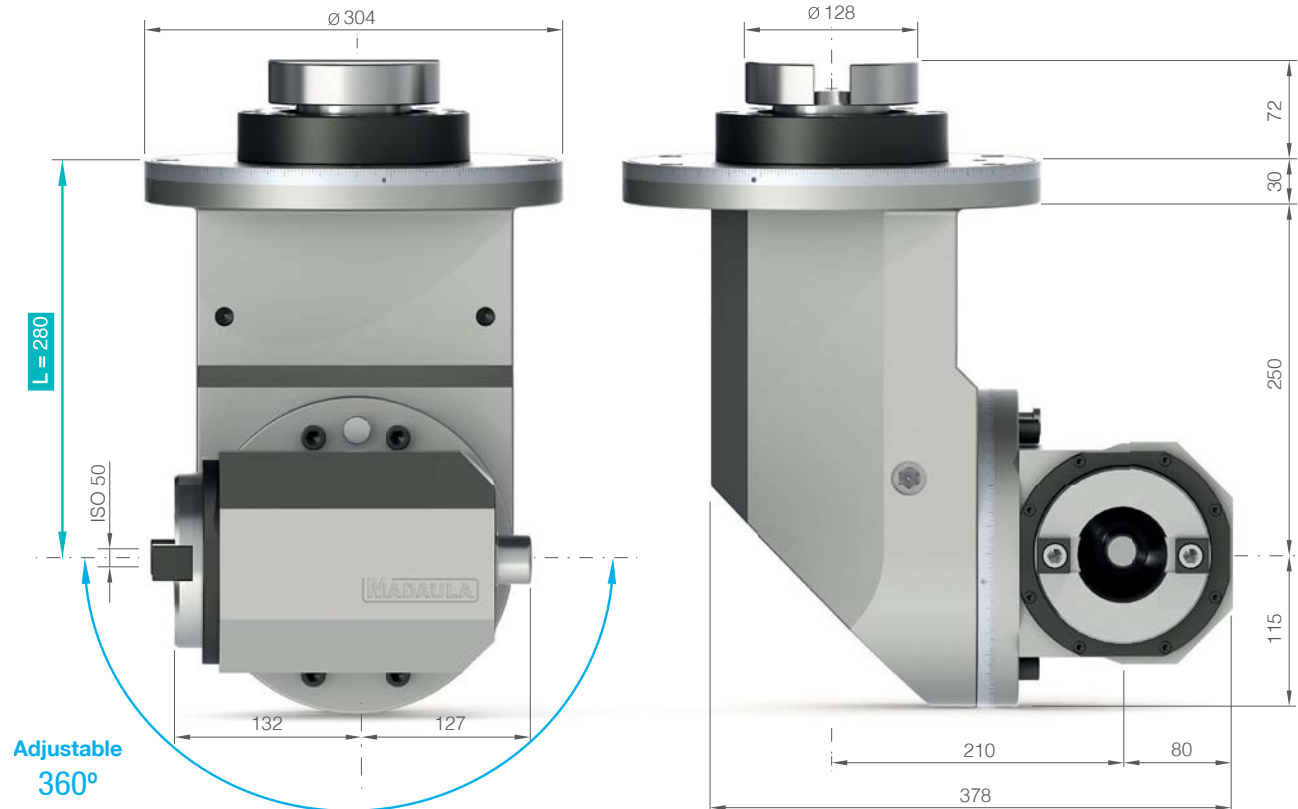
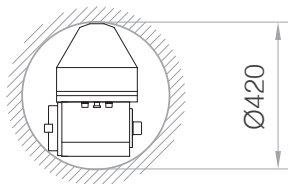

Flange mounted giving an increased rigidity.

Rigidité accrue lors du montage par flasque sur la machine.

Erhöhte Starrheit durch Flanscheinbau direkt an die Maschine.



Standard Equipment

Standard / Standard

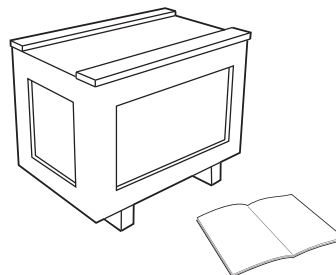

Optional Equipment

Optionel / Option

Internal air pressure

Suppression d'air interne / Sperrluft

bar/psi max 0.3/4

Quick change system

Système de changement rapide / Schnellwechselfaufnahme



Alternative output HSK 63

Sortie alternative HSK 63 / Alternative ausgänge HSK 63

See page 55

Technical Data

Caractéristiques techniques / Technische Daten

	ER-16A / 10 mm
R.P.M max	8.000
	7.5 kg
	1:1
KW	3.5 kW
Nm max	25 Nm
Rotation	in ≠ out
Coolant max pressure	80 bar / 1160 psi

Always run wet

Tourner toujours avec arrosage /
Nicht ohne Kühlmittel fahren

Filtration

Filtration / Filtration 40 µm

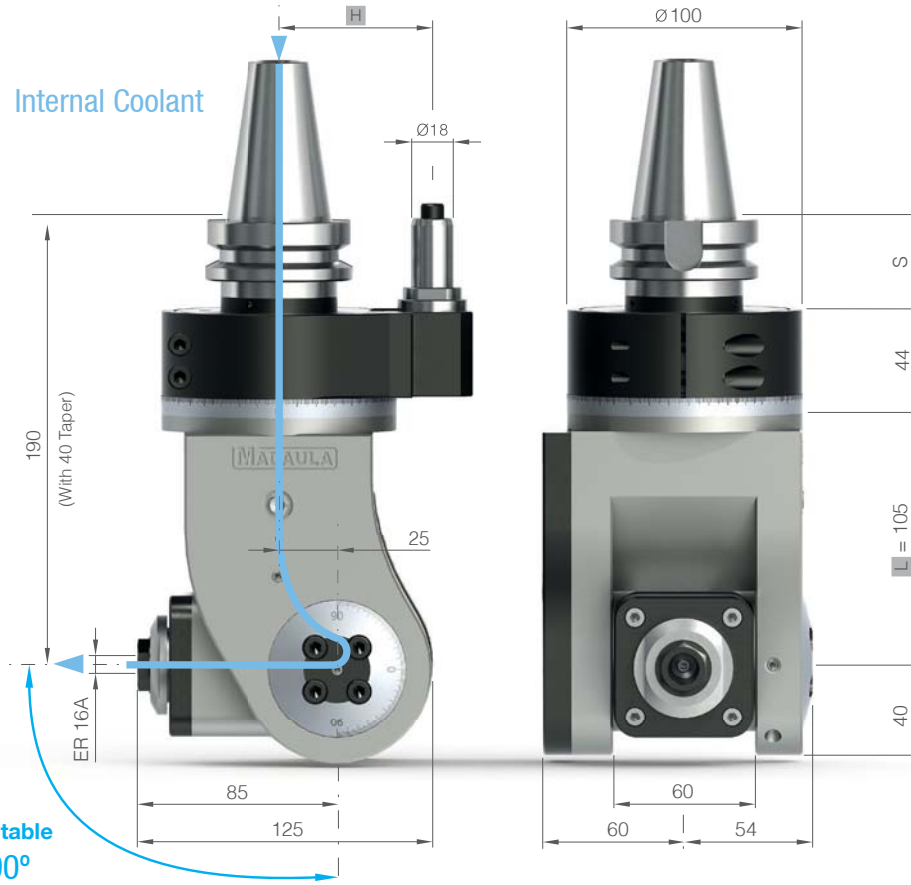
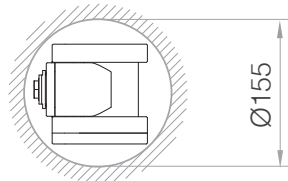

Taper

Cône / Kegel

Size

Taille / Größe

H

S

Taper	Size	H	S
DIN 69871 / 2080	40/50	65/80	40
CAT	40/50	65/80	40
MAS-BT	40/50	65/80	40/50
HSK	63/100	65/80	40/50
CAPTO	C6/C8	65/80	40/50
KM	63/100	65/80	40/50

Standard Equipment

Standard / Standard

Optional Equipment

Optionel / Option

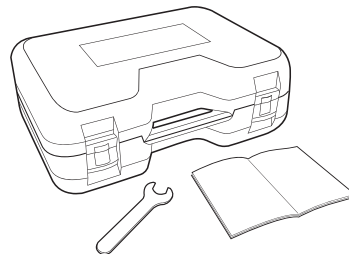

Stop Block

Bloc d'arrêt / Anschlag-Block

See page 55 

Collets

Pinces / Spannzangen

See page 56 

CAR 1 IC COOLANT

±90° Adjust.

Technical Data

Caractéristiques techniques / Technische Daten

	ER-25A / 16 mm
R.P.M max	4.000
	16.5 kg
	1:1
KW	5 kW
Nm max	14 Nm
Rotation	in ≠ out
Coolant max pressure	80 bar / 1160 psi

Always run wet

Tourner toujours avec arrosage /
Nicht ohne Kühlmittel fahren

Filtration

Filtration / Filtration 40 µm

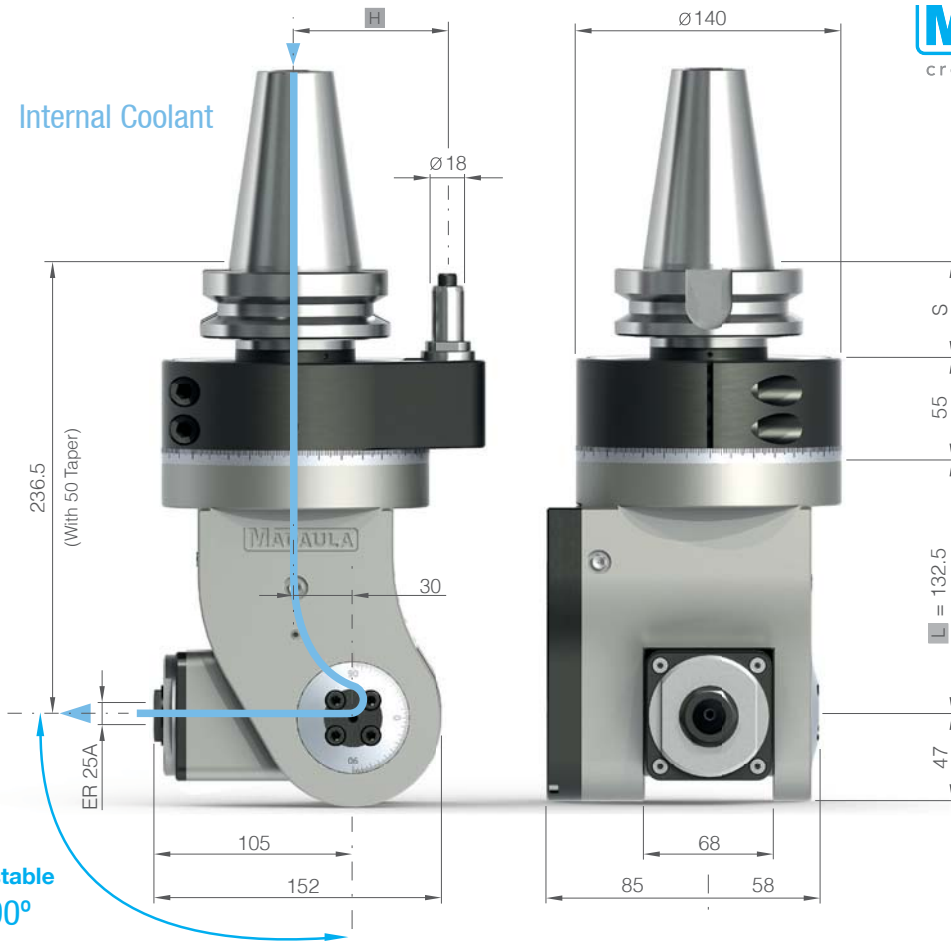
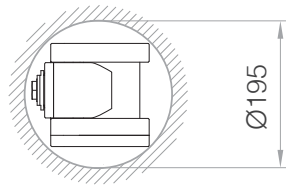

Taper Cône / Kegel	Size Taille / Größe	H	S
DIN 69871 / 2080	50	80	40
CAT	50	80	40
MAS-BT	50	80	50
HSK	80/100	80	40/50
CAPTO	C8	80	50
KM	80/100	80	40/50

Standard Equipment

Standard / Standard

Optional Equipment

Optionel / Option

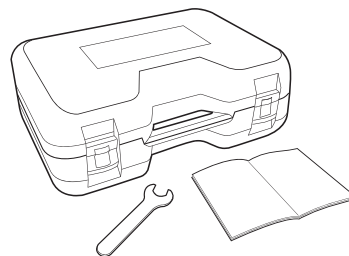

Stop Block

Bloc d'arrêt / Anschlag-Block

See page 55

Collets

Pinces / Spannzangen

See page 56

CAR 2IC COOLANT $\pm 90^\circ$ Adjust.

Technical Data

Caractéristiques techniques / Technische Daten

	ER-32A / 20 mm
R.P.M max	4.000
	25 kg
	1:1
KW	6 kW
Nm max	22 Nm
Rotation	in \neq out
Coolant max pressure	80 bar / 1160 psi

Always run wet

Tourner toujours avec arrosage /
Nicht ohne Kühlmittel fahren

Filtration

Filtration / Filtration 40 μ m

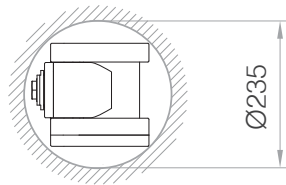

Taper	Size	H	S
Cône / Kegel	Taille / Größe		
DIN 69871 / 2080	50	80	40
CAT	50	80	40
MAS-BT	50	80	50
HSK	80/100	80	40/50
CAPTO	C8	80	50
KM	80/100	80	40/50

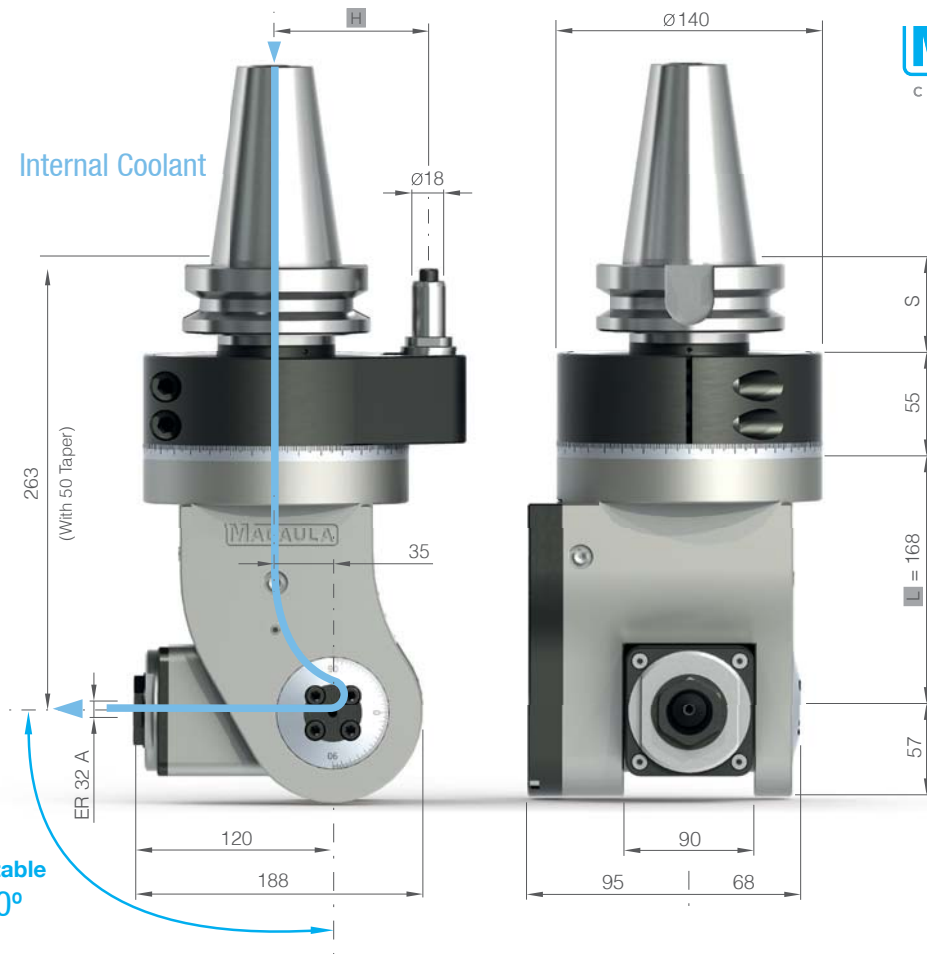

MADAULA
creative solutions

Standard Equipment

Standard / Standard

Optional Equipment

Optionel / Option

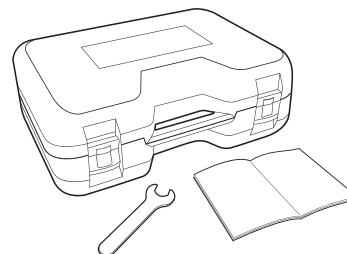

Stop Block

Bloc d'arrêt / Anschlag-Block

See page 55

Collets

Pinces / Spannzangen

See page 56

CAF



0 to 90°
Fixed angle

MADAULA
creative solutions

Technical Data

Caractéristiques techniques / Technische Daten

	ER-16A / 10 mm
R.P.M max	8.000
	3.8 kg
	1:1
KW	3.5 kW
Nm max	12 Nm
Rotation	in ≠ out

L / H / α

Other measures under request

Autres mesures sur demande

Weitere Maßnahmen auf Anfrage

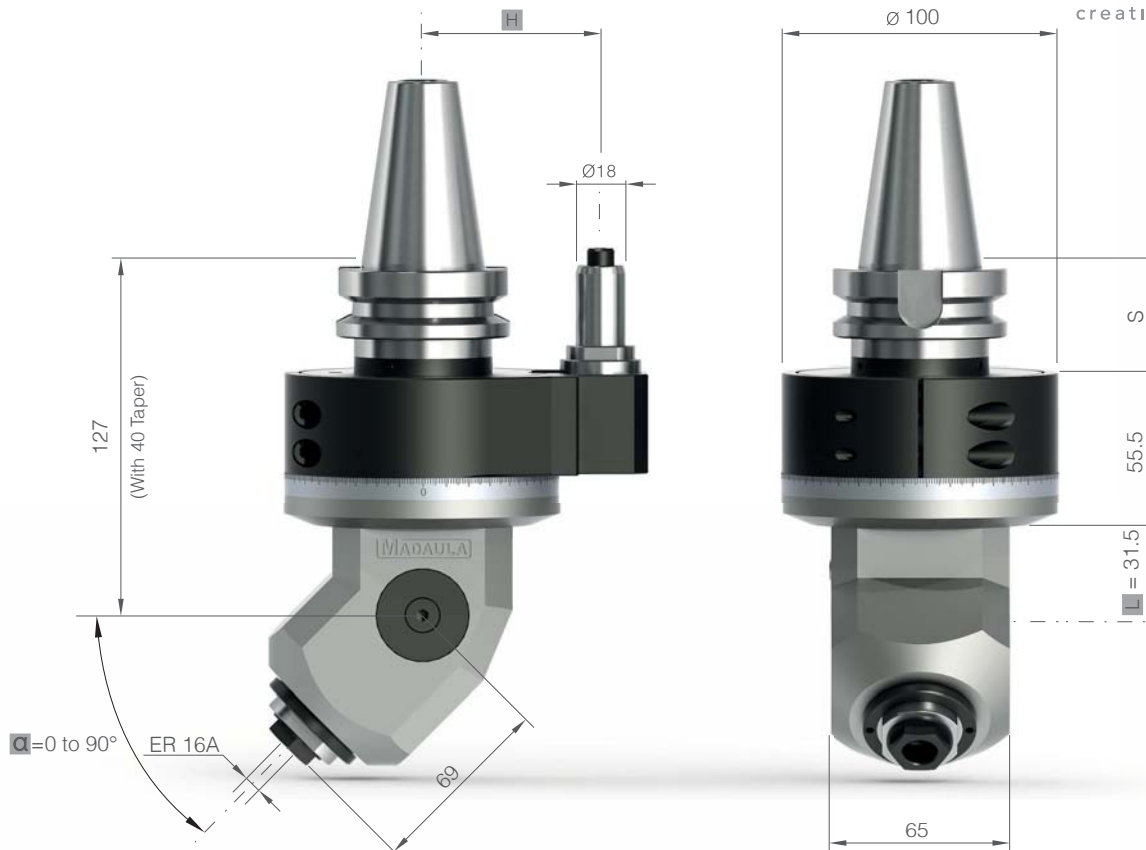

Taper Cône / Kegel	Size Taille / Größe	H	S
-----------------------	------------------------	---	---

DIN 69871 / 2080	30/40/50	55/65/80	40
CAT	30/40/50	55/65/80	40
MAS-BT	30/40/50	55/65/80	40/40/50
HSK	50/63/100	55/65/80	40/40/50
CAPTO	C5/C6/C8	55/65/80	40/40/50
KM	50/63/100	55/65/80	40/40/50

Standard Equipment

Standard / Standard

Optional Equipment

Optionel / Option

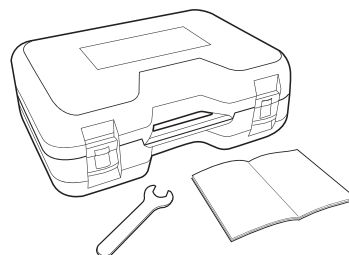

Stop Block

Bloc d'arrêt / Anschlag-Block

See page 55

Collets

Pinces / Spannzangen

See page 56

Coolant through index pin

Arrosage par le doigt d'indexage / Kühlmittelzufuhr durch bolzen

bar/psi max 12/175

Alternative outputs

Sortie alternative / Alternative ausgänge

See page 55

CAF 1

1

0 to 90° Fixed angle

Technical Data

Caractéristiques techniques / Technische Daten

	ER-25 / 16 mm
R.P.M max	4.000
	5.8 kg
	1:1
KW	5 kW
Nm max	12 Nm
Rotation	in ≠ out

L / H / α

Other measures under request

Autres mesures sur demande

Weitere Maßnahmen auf Anfrage

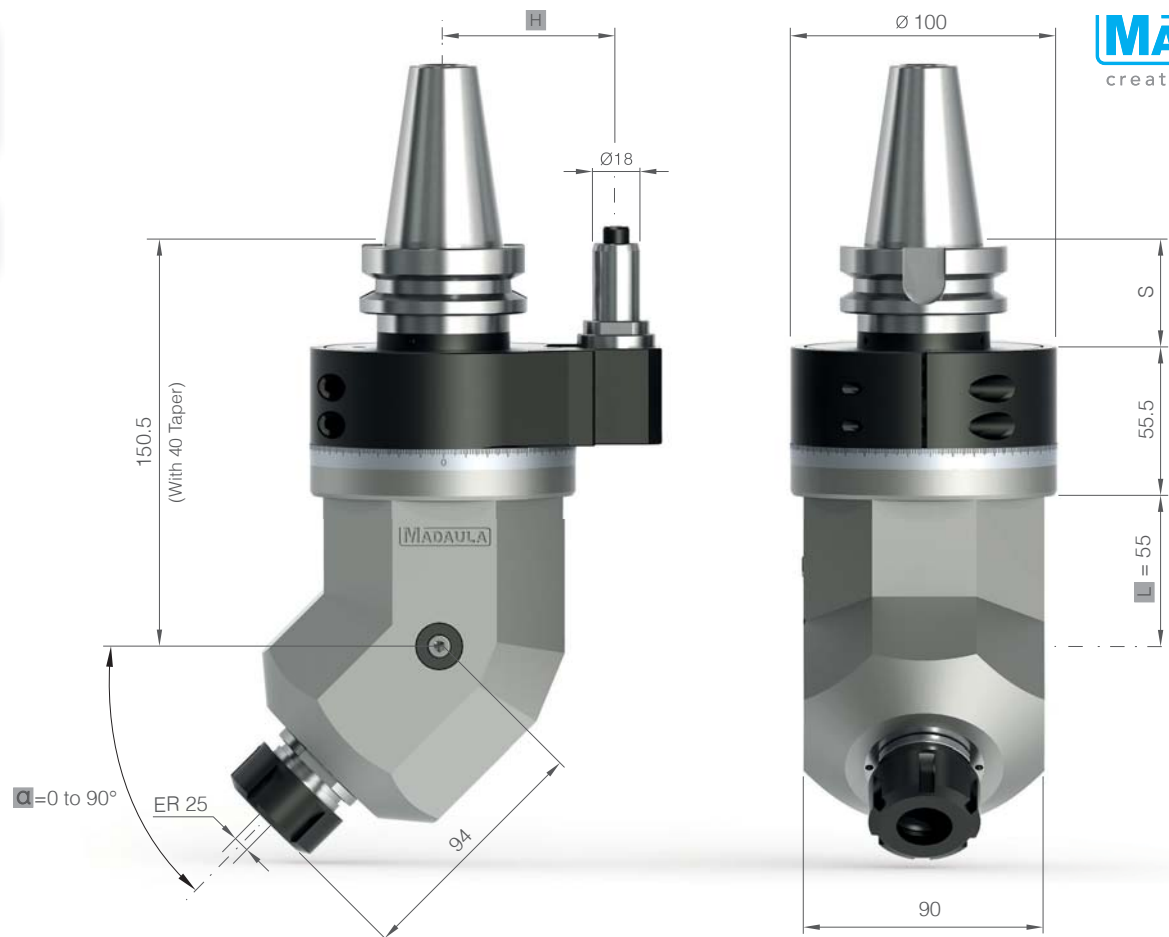

MADAULA

creative solutions

Taper

Cône / Kegel

Size

Taille / Größe

H

S

Taper	Size	H	S
DIN 69871 / 2080	40/50	65/80	40
CAT	40/50	65/80	40
MAS-BT	40/50	65/80	40/50
HSK	63/100	65/80	40/50
CAPTO	C6/C8	65/80	40/50
KM	63/100	65/80	40/50

Standard Equipment

Standard / Standard

Optional Equipment

Optionel / Option

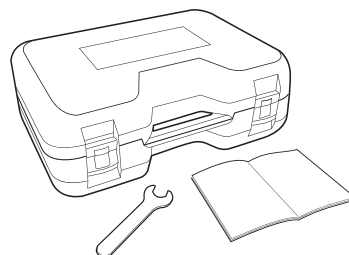

Stop Block

Bloc d'arrêt / Anschlag-Block

See page 55 

Collets

Pinces / Spannzangen

See page 56 

Coolant through index pin

Arrosage par le doigt d'indexage / Kühlmittelzufuhr durch bolzen

bar/psi max 12/175

Alternative outputs



Sortie alternative / Alternative ausgänge

See page 55 

CAF 2 0 to 90° Fixed angle

Technical Data

Caractéristiques techniques / Technische Daten

	ER-32 / 20 mm
R.P.M max	Heavy duty bearings 4.000
	12.5 kg
	1:1
KW	6 kW
Nm max	22 Nm
Rotation	in ≠ out

L / H / α

Other measures under request

Autres mesures sur demande

Weitere Maßnahmen auf Anfrage

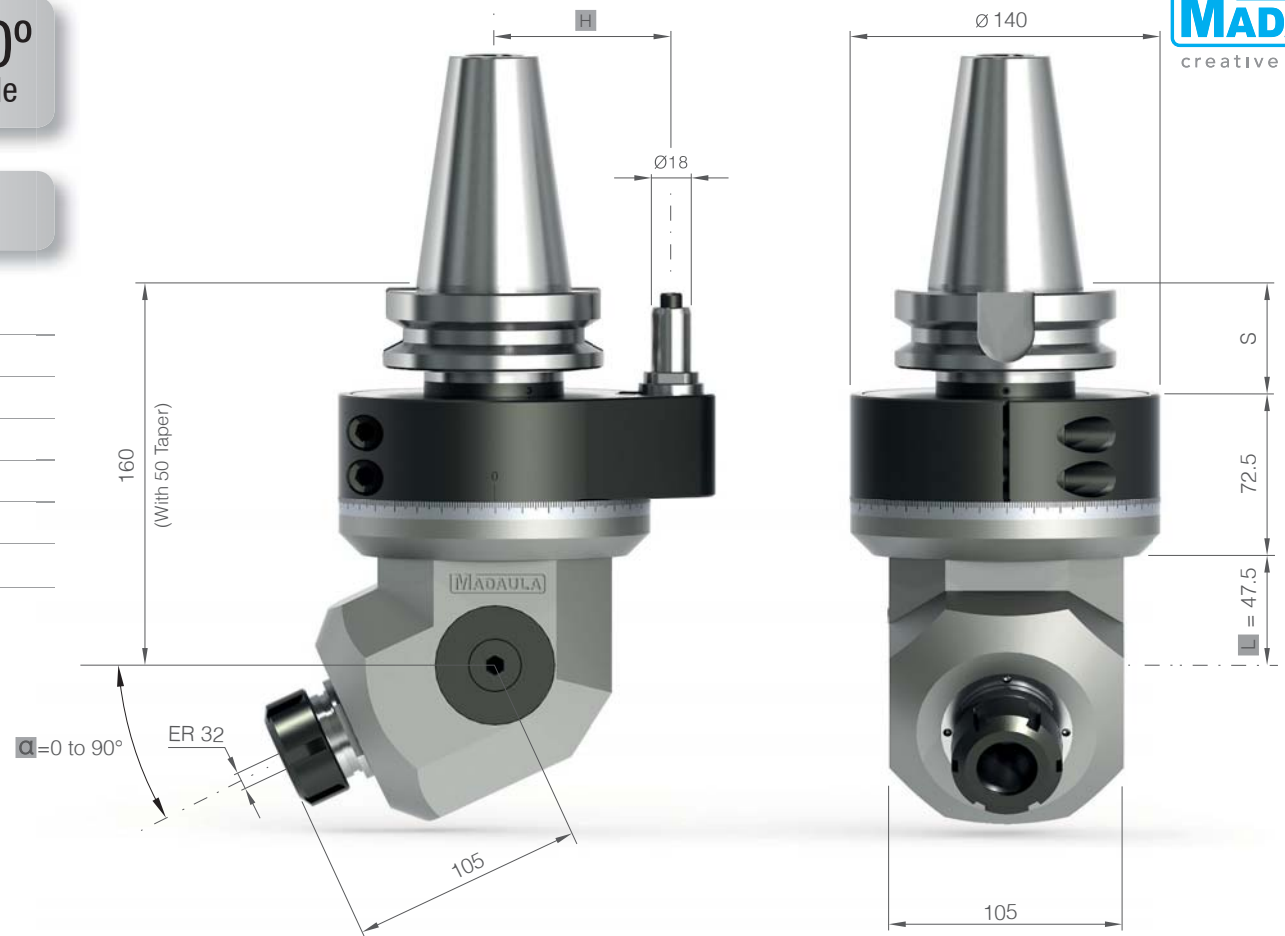

MADAULA
creative solutions

Taper Cône / Kegel	Size Taille / Größe	H	S
DIN 69871 / 2080	50	80	40
CAT	50	80	40
MAS-BT	50	80	50
HSK	80/100	80	40/50
CAPTO	C8	80	50
KM	80/100	80	40/50

Standard Equipment

Standard / Standard

Optional Equipment

Optionel / Option

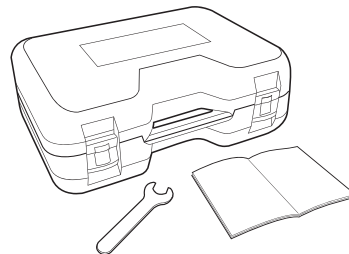

Stop Block

Bloc d'arrêt / Anschlag-Block

See page 55 

Collets

Pinces / Spannzangen

See page 56 

Coolant through index pin

Arrosage par le doigt d'indexage / Kühlmittelzufuhr durch bolzen

bar/psi max 12/175

High speed option RPM max

Haute vitesse en option RPM / Hochgeschwindigkeit optional UPM max

6.000

CAF



0 to 90°
Fixed angle

Technical Data

Caractéristiques techniques / Technische Daten

		ER-40 / 26 mm
R.P.M max	Heavy duty bearings	3.500
		17.5 kg
		1:1
KW		10 kW
Nm max		40 Nm
Rotation		in ≠ out

L / H / α

Other measures under request

Autres mesures sur demande

Weitere Maßnahmen auf Anfrage

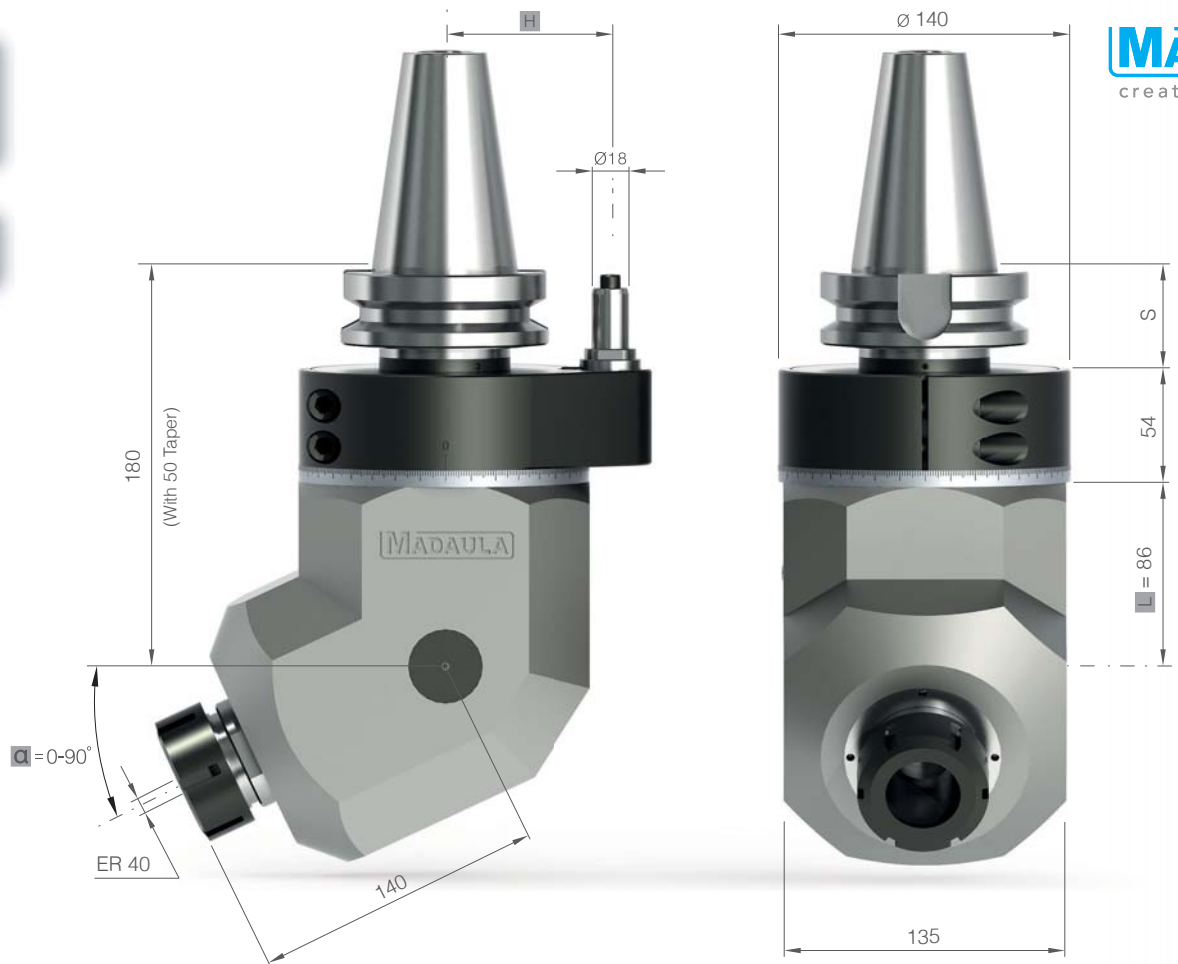

MADAULA
creative solutions

Taper Cône / Kegel	Size Taille / Größe	H	S
DIN 69871 / 2080	50	80	40
CAT	50	80	40
MAS-BT	50	80	50
HSK	80/100	80	40/50
CAPTO	C8	80	50
KM	80/100	80	40/50

Standard Equipment

Standard / Standard

Optional Equipment

Optionel / Option

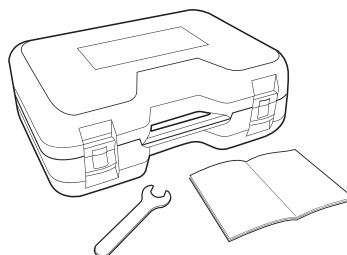

Stop Block

Bloc d'arrêt / Anschlag-Block

See page 55

Collets

Pinces / Spannzangen

See page 56

Coolant through index pin

Arrosage par le doigt d'indexage / Kühlmittelzufuhr durch bolzen

bar/psi max 12/175

High speed option RPM max



Haute vitesse en option RPM / Hochgeschwindigkeit optional UPM max

6.000

CAFS 0 to 90° Fixed offset

Technical Data

Caractéristiques techniques / Technische Daten

	ER-16 / 10 mm
R.P.M max	8.000
	2.6 kg
	1:1
KW	3.5 kW
Nm max	14 Nm
Rotation	in ≠ out

L / H / α

Other measures under request

Autres mesures sur demande

Weitere Maßnahmen auf Anfrage

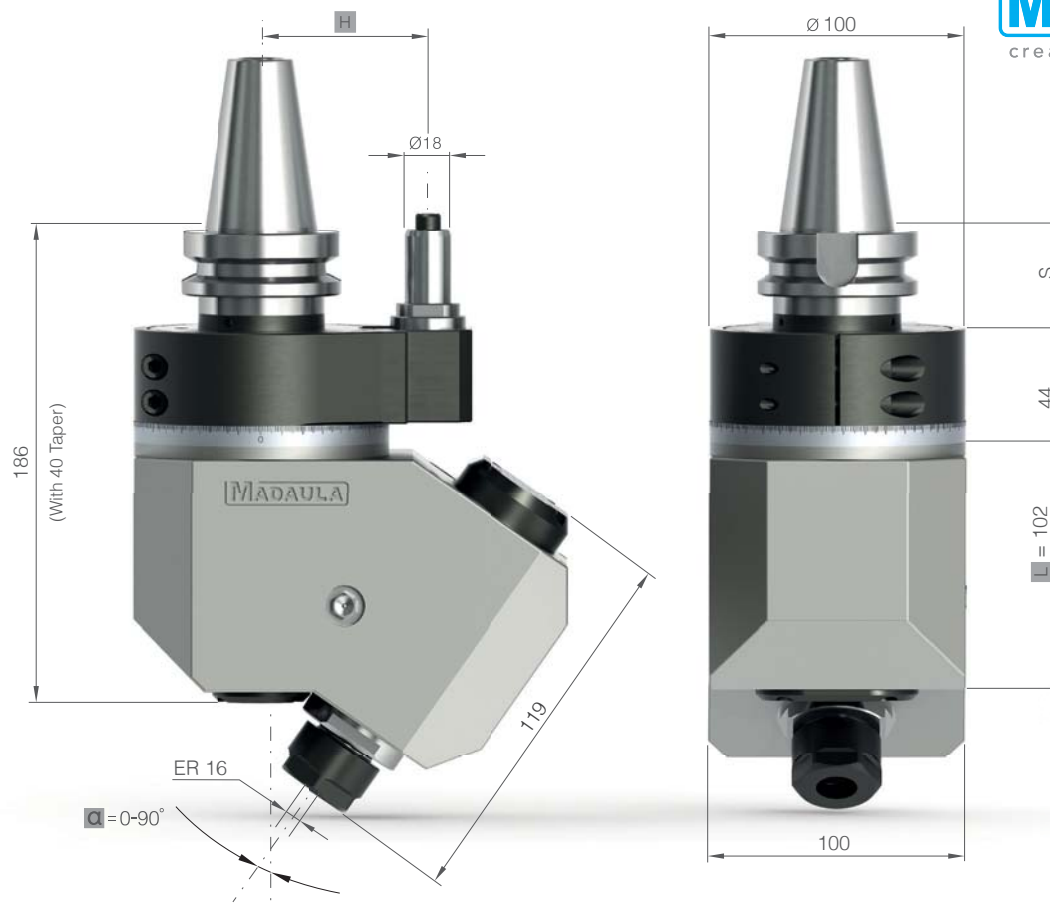

Taper Cône / Kegel	Size Taille / Größe	H	S
DIN 69871 / 2080	30/40/50	55/65/80	40
CAT	30/40/50	55/65/80	40
MAS-BT	30/40/50	55/65/80	40/40/50
HSK	50/63/100	55/65/80	40/40/50
CAPTO	C5/C6/C8	55/65/80	40/40/50
KM	50/63/100	55/65/80	40/40/50

Standard Equipment

Standard / Standard

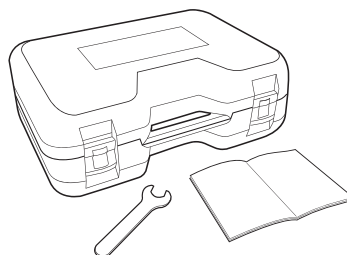

Optional Equipment

Optionel / Option

Stop Block

Bloc d'arrêt / Anschlag-Block

See page 55 

Collets

Pinces / Spannzangen

See page 56 

Coolant through index pin

Arrosage par le doigt d'indexage / Kühlmittelzufuhr durch bolzen



bar/psi max 12/175

CAFS 1

0 to 90°
Fixed offset

Technical Data

Caractéristiques techniques / Technische Daten

	ER-25 / 16 mm
R.P.M max	4.000
	5.5 kg
	1:1
KW	5 kW
Nm max	30 Nm
Rotation	in ≠ out

L / H / α

Other measures under request

Autres mesures sur demande

Weitere Maßnahmen auf Anfrage

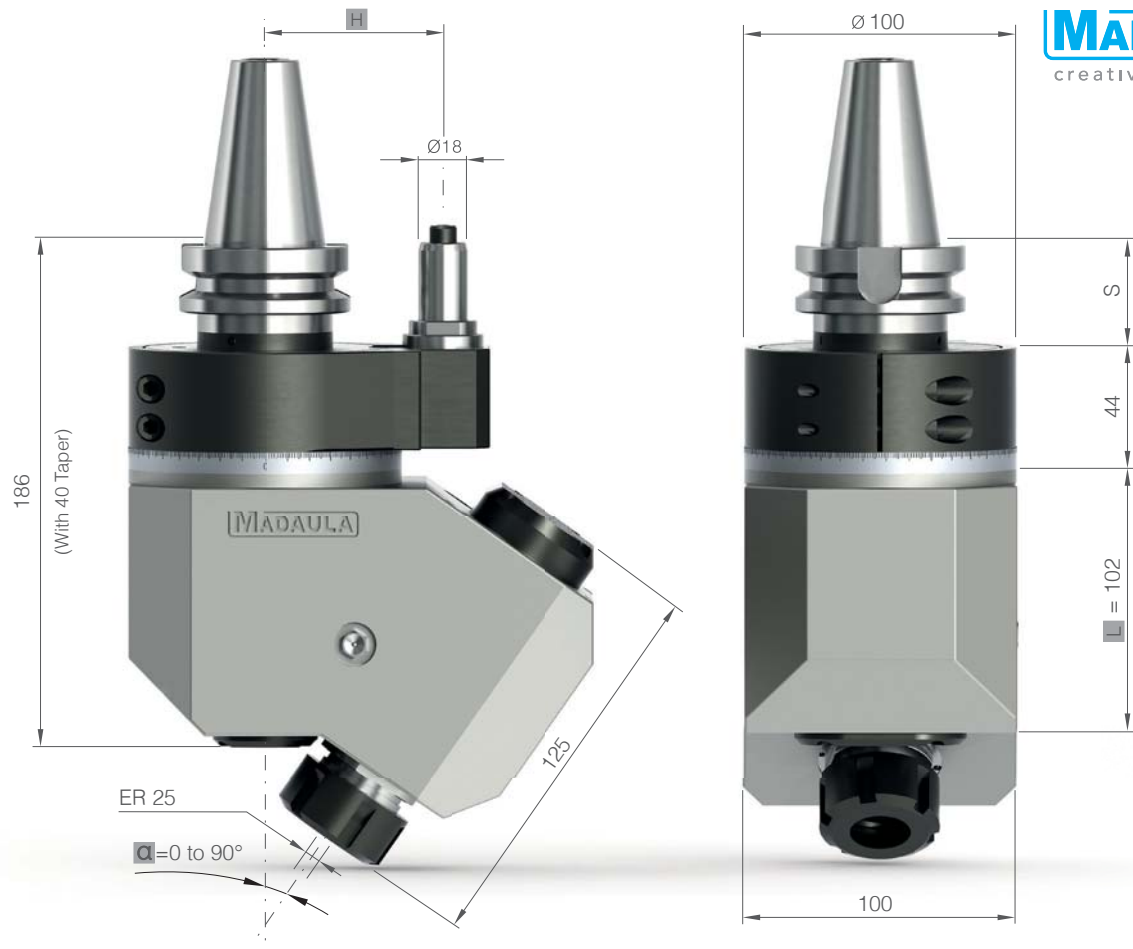

MADAULA
creative solutions

Taper Cône / Kegel	Size Taille / Größe	H	S
DIN 69871 / 2080	40/50	65/80	40
CAT	40/50	65/80	40
MAS-BT	40/50	65/80	40/50
HSK	63/100	65/80	40/50
CAPTO	C6/C8	65/80	40/50
KM	63/100	65/80	40/50

Standard Equipment

Standard / Standard

Optional Equipment

Optionel / Option

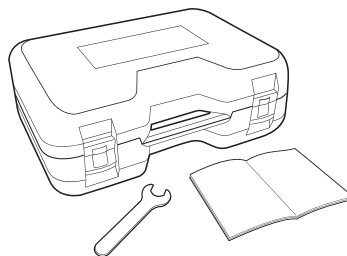

Stop Block

Bloc d'arrêt / Anschlag-Block

See page 55 

Collets

Pinces / Spannzangen

See page 56 

Coolant through index pin



Arrosage par le doigt d'indexage / Kühlmittelzufuhr durch bolzen

bar/psi max 12/175

CAFS 2 0 to 90° Fixed offset

Technical Data

Caractéristiques techniques / Technische Daten

		ER-32 / 20 mm
R.P.M max	Heavy duty bearings	4.000
		11.3 kg
		1:1
KW		6 kW
Nm max		50 Nm
Rotation		in ≠ out

L / H / α

Other measures under request

Autres mesures sur demande

Weitere Maßnahmen auf Anfrage

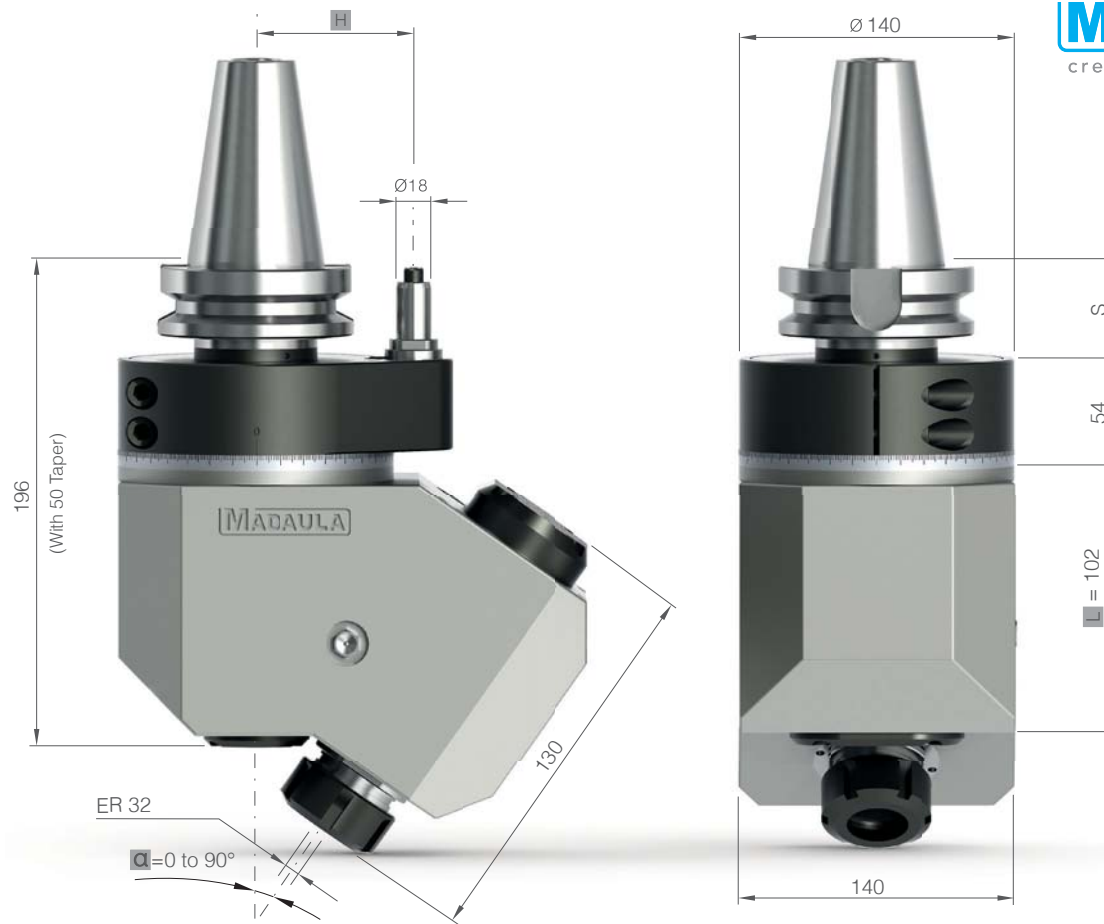

MADAULA
creative solutions

Taper Cône / Kegel	Size Taille / Größe	H	S
DIN 69871 / 2080	50	80	40
CAT	50	80	40
MAS-BT	50	80	50
HSK	80/100	80	40/50
CAPTO	C8	80	50
KM	80/100	80	40/50

Standard Equipment

Standard / Standard

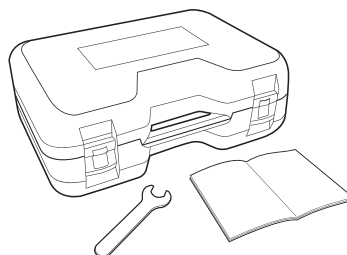

Optional Equipment

Optionel / Option

Stop Block

Bloc d'arrêt / Anschlag-Block

See page 55 

Collets

Pinces / Spannzangen

See page 56 

Coolant through index pin

Arrosage par le doigt d'indexage / Kühlmittelzufuhr durch bolzen

bar/psi max 12/175

High speed option RPM max

Haute vitesse en option RPM / Hochgeschwindigkeit optional UPM max

6.000

CAFS 3 0 to 90° Fixed offset

Technical Data

Caractéristiques techniques / Technische Daten

	ER-40 / 26 mm
R.P.M max	Heavy duty bearings 3.500
	15.8 kg
	1:1
KW	10 kW
Nm max	80 Nm
Rotation	in ≠ out

L / H / α

Other measures under request

Autres mesures sur demande

Weitere Maßnahmen auf Anfrage

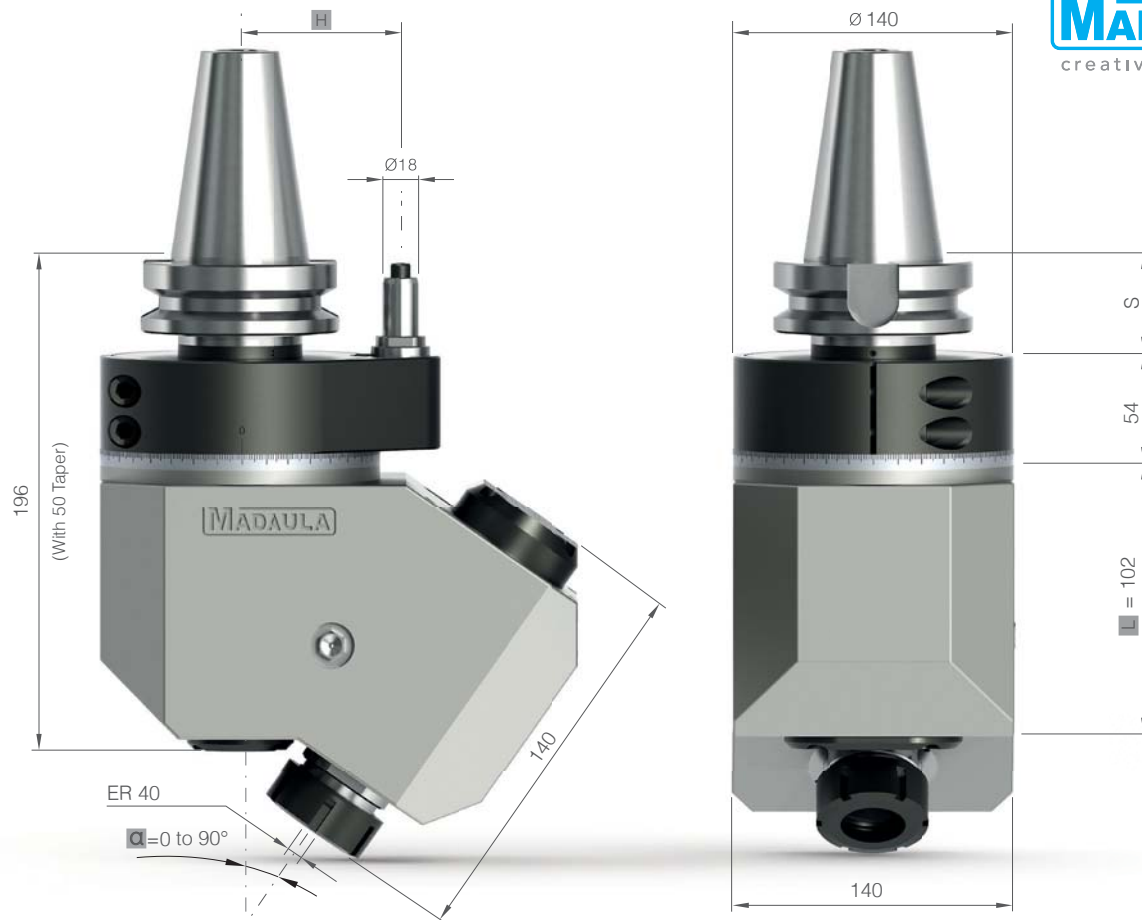

MADAULA
creative solutions

Taper Cône / Kegel	Size Taille / Größe	H	S
DIN 69871 / 2080	50	80	40
CAT	50	80	40
MAS-BT	50	80	50
HSK	80/100	80	40/50
CAPTO	C8	80	50
KM	80/100	80	40/50

Standard Equipment

Standard / Standard

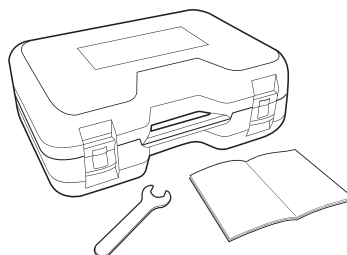

Optional Equipment

Optionel / Option

Stop Block

Bloc d'arrêt / Anschlag-Block

See page 55 

Collets

Pinces / Spannzangen

See page 56 

Coolant through index pin

Arrosage par le doigt d'indexage / Kühlmittelzufuhr durch bolzen

bar/psi max 12/175



High speed option RPM max

Haute vitesse en option RPM / Hochgeschwindigkeit optional UPM max

6.000

Technical Data

Caractéristiques techniques / Technische Daten

	CAFS 0 IC	CAFS 1 IC	CAFS 2 IC	CAFS 3 IC
	ER-16	ER-25	ER-32	ER-40
R.P.M max	8.000	4.000	4.000	3.500
	3.5 kg	5.9 kg	11.7 kg	16.2 kg
	1:1	1:1	1:1	1:1
KW	3.5 kW	5 kW	6 kW	10 kW
Nm max	14 Nm	30 Nm	50 Nm	80 Nm
Rotation	in ≠ out	in ≠ out	in ≠ out	in ≠ out
Max. pressure	80 bar	80 bar	80 bar	80 bar

Other measures under request. See page 37 to 40.

Autres mesures sur demande. Voir page 37 à 40.

Weitere Maßnahmen auf Anfrage. Siehe Seite 37 bis 40.

Always run wet

Tourner toujours avec arrosage / Nicht ohne Kühlmittel fahren

Filtration

Filtration / Filtration

40 µm

Always keep below the max. speed

Tourner toujours au dessous de la vitesse maxi /

Immer unter der maximalen Geschwindigkeit zu halten

Alternative outputs

Sorties alternatives / Alternative Ausgänge

See page 55



CAFS 0 IC



CAFS 1 IC

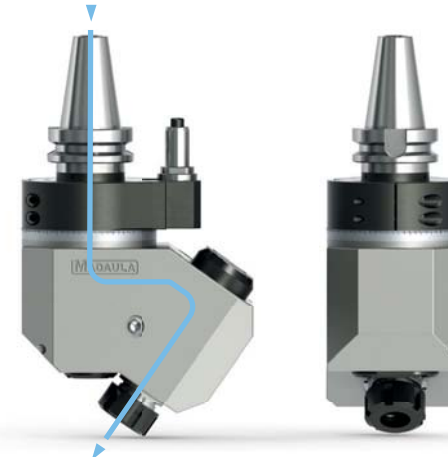

CAFS 2 IC



CAFS 3 IC



CAP



**Slim
design 90°**

Technical Data

Caractéristiques techniques / Technische Daten

Special tool max. Ø4 mm

R.P.M max 6.000

KG 4 kg

1:1

KW 0.9 kW

Nm max 3 Nm

Rotation in = out (A-B)

in ≠ out (C)

L / H

Other measures under request

Autres mesures sur demande

Weitere Maßnahmen auf Anfrage

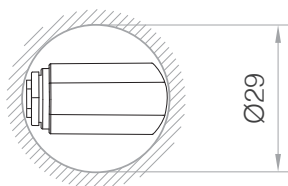

Taper	Size	H	S
-------	------	---	---

Cône / Kegel

Taille / Größe

DIN 69871 / 2080	40/50	65/80	40
------------------	-------	-------	----

CAT	40/50	65/80	40
-----	-------	-------	----

MAS-BT	40/50	65/80	40/50
--------	-------	-------	-------

HSK	63/100	65/80	40/50
-----	--------	-------	-------

CAPTO	C6/C8	65/80	40/50
-------	-------	-------	-------

KM	63/100	65/80	40/50
----	--------	-------	-------



MADAULA
creative solutions

L	A	50
	B	75
	C	100

Standard Equipment

Standard / Standard

Optional Equipment

Optionel / Option

Stop Block

Bloc d'arrêt / Anschlag-Block

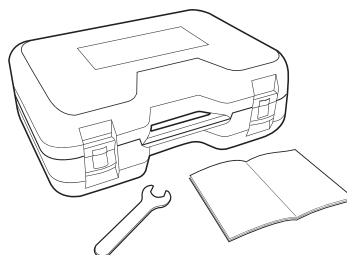

See page 55



CAP 1 Slim design 90°

Technical Data

Caractéristiques techniques / Technische Daten

	ER-8 / 5 mm
R.P.M max	6.000
	5 kg
	1:1
KW	1 kW
Nm max	3 Nm
Rotation	in = out (B-C) in ≠ out (A)

L / H

Other measures under request

Autres mesures sur demande

Weitere Maßnahmen auf Anfrage

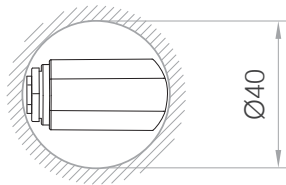

L	A	50
	B	75
	C	100

Taper	Size	H	S
Cône / Kegel	Taille / Größe		

DIN 69871 / 2080	40/50	65/80	40
CAT	40/50	65/80	40
MAS-BT	40/50	65/80	40/50
HSK	63/100	65/80	40/50
CAPTO	C6/C8	65/80	40/50
KM	63/100	65/80	40/50

Standard Equipment

Standard / Standard

Optional Equipment

Optionel / Option

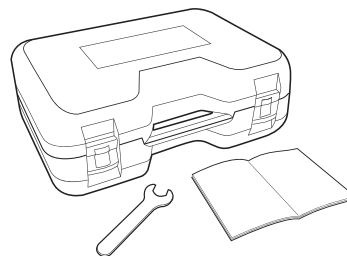

Stop Block

Bloc d'arrêt / Anschlag-Block

See page 55



Collets

Pinces / Spannzangen

See page 56



Coolant through index pin

Arrosage par le doigt d'indexage / Kühlmittelzufuhr durch bolzen

bar/psi max 12/175



CAP

2 Slim design 90°

MADAULA
creative solutions

Technical Data

Caractéristiques techniques / Technische Daten

	ER-11M / 7 mm
R.P.M max	6.000
	5.4 kg
	1:1
KW	1.5 kW
Nm max	6 Nm
Rotation	in = out (B-C) in ≠ out (A)

L / H

Other measures under request

Autres mesures sur demande

Weitere Maßnahmen auf Anfrage

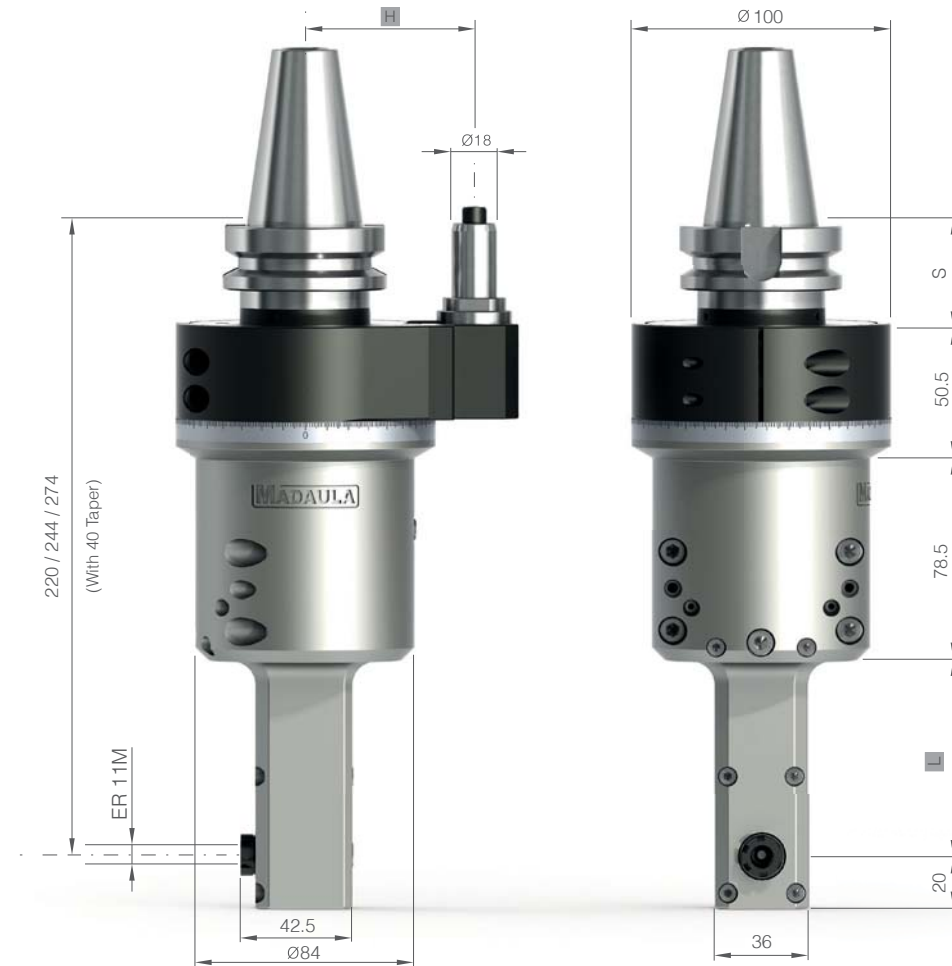
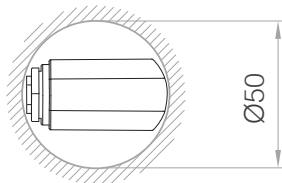

L	A	50
	B	75
	C	100

Taper Cône / Kegel	Size Taille / Größe	H	S
------------------------------	-------------------------------	----------	----------

DIN 69871 / 2080	40/50	65/80	40
CAT	40/50	65/80	40
MAS-BT	40/50	65/80	40/50
HSK	63/100	65/80	40/50
CAPTO	C6/C8	65/80	40/50
KM	63/100	65/80	40/50

Standard Equipment

Standard / Standard

Optional Equipment

Optionel / Option

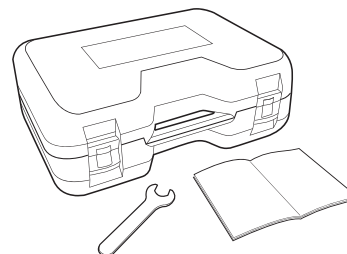

Stop Block

Bloc d'arrêt / Anschlag-Block

See page 55 

Collets

Pinces / Spannzangen

See page 56 

Coolant through index pin

Arrosage par le doigt d'indexage / Kühlmittelzufuhr durch bolzen



bar/psi max 12/175

CAP

3 Slim design 90°

Technical Data

Caractéristiques techniques / Technische Daten

	ER-20A / 13 mm
R.P.M max	Heavy duty bearings 4.000
	6 / 8 kg
	1:1
KW	7 kW
Nm max	35 Nm
Rotation	in = out (A-C) in ≠ out (B)

L / H

Other measures under request

Autres mesures sur demande

Weitere Maßnahmen auf Anfrage

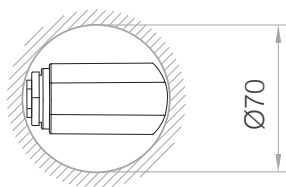

MADAULA
creative solutions

L	A	60
	B	95
	C	130

Taper	Size	H	S
Cône / Kegel	Taille / Größe		

DIN 69871 / 2080	40/50	65/80	40
CAT	40/50	65/80	40
MAS-BT	40/50	65/80	40/50
HSK	63/100	65/80	40/50
CAPTO	C6/C8	65/80	40/50
KM	63/100	65/80	40/50

Standard Equipment

Standard / Standard

Optional Equipment

Optionel / Option

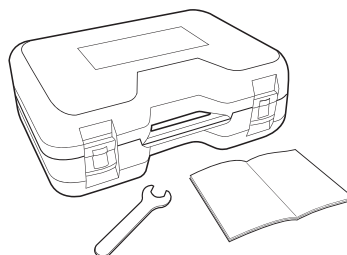

Stop Block

Bloc d'arrêt / Anschlag-Block

See page 55 

Collets

Pinces / Spannzangen

See page 56 

Coolant through index pin

Arrosage par le doigt d'indexage / Kühlmittelzufuhr durch bolzen

bar/psi max 12/175

High speed option RPM max

Haute vitesse en option RPM / Hochgeschwindigkeit optional UPM max

8.000

CAP 4 Slim design 90°

Technical Data

Caractéristiques techniques / Technische Daten

	ER-25A / 16 mm
R.P.M max	Heavy duty bearings 4.000
	12 kg
	1:1
KW	7 kW
Nm max	40 Nm
Rotation	in = out (A-C) in ≠ out (B)

L / H

Other measures under request

Autres mesures sur demande
Weitere Maßnahmen auf Anfrage

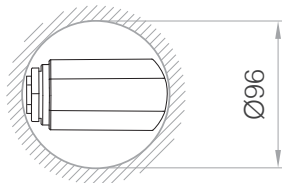

L	A	64
	B	120
	C	175

Taper	Size	H	S
Cône / Kegel	Taille / Größe		

DIN 69871 / 2080	50	80	40
CAT	50	80	40
MAS-BT	50	80	50
HSK	80/100	80	40/50
CAPTO	C8	80	50
KM	80/100	80	40/50

Standard Equipment

Standard / Standard

Optional Equipment

Optionel / Option

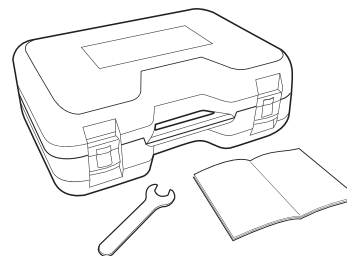

Stop Block

Bloc d'arrêt / Anschlag-Block

See page 55

Collets

Pinces / Spannzangen

See page 56

Coolant through index pin

Arrosage par le doigt d'indexage / Kühlmittelzufuhr durch bolzen

bar/psi max 12/175

High speed option RPM max



Haute vitesse en option RPM / Hochgeschwindigkeit optional UPM max

8.000

CAP 5 Slim design 90°

Technical Data

Caractéristiques techniques / Technische Daten

		ER-32A / 20 mm
R.P.M max	Heavy duty bearings	4.000
		14 kg
		1:1
KW		16 kW
Nm max		75 Nm
Rotation		in = out (A-C) in ≠ out (B)

L / H

Other measures under request

Autres mesures sur demande

Weitere Maßnahmen auf Anfrage

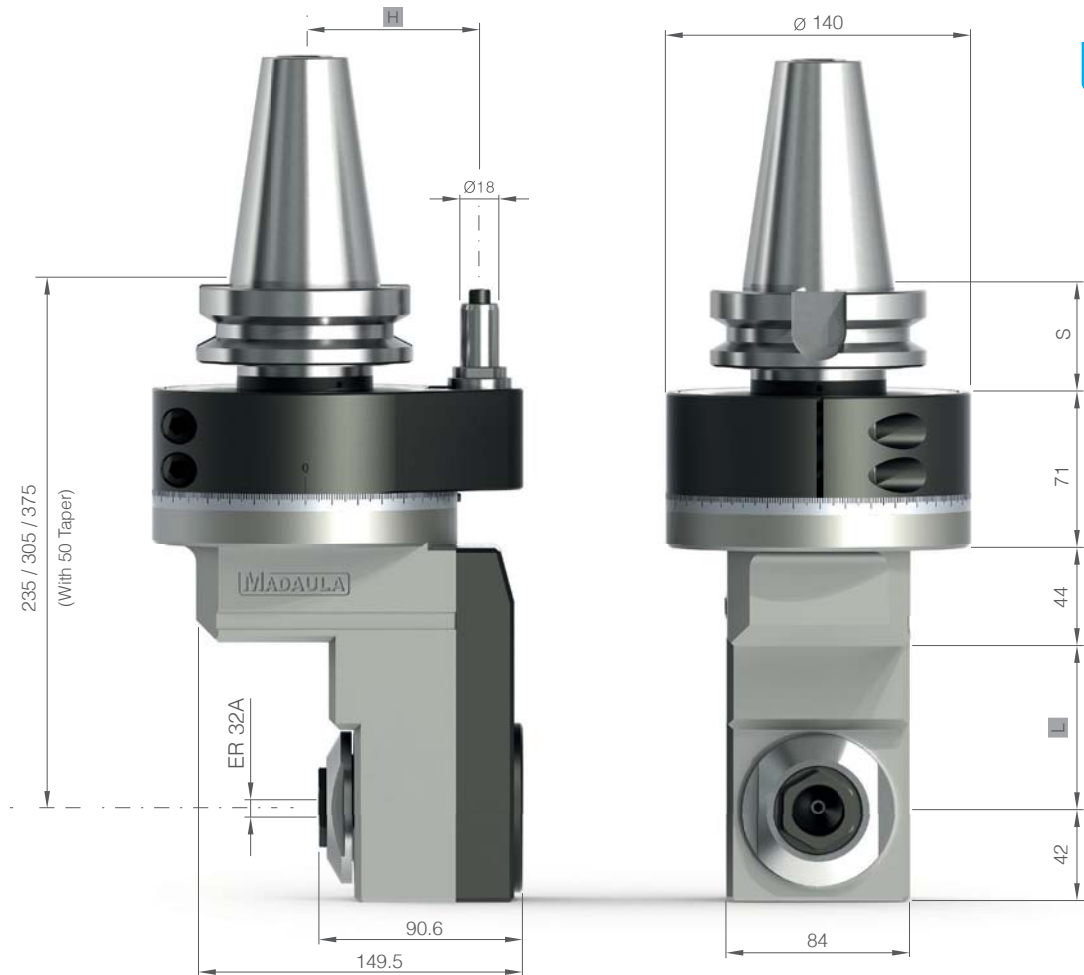
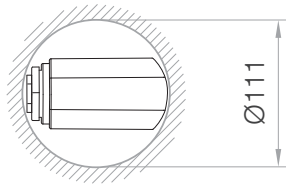

MADAULA
creative solutions

L	A	80
	B	150
	C	220

Taper	Size	H	S
Cône / Kegel	Taille / Größe		

DIN 69871 / 2080	50	80	40
CAT	50	80	40
MAS-BT	50	80	50
HSK	80/100	80	40/50
CAPTO	C8	80	50
KM	80/100	80	40/50

Standard Equipment

Standard / Standard

Optional Equipment

Optionel / Option

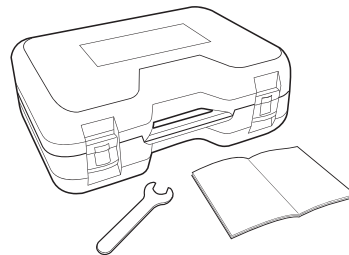

Stop Block

Bloc d'arrêt / Anschlag-Block

See page 55 

Collets

Pinces / Spannzangen

See page 56 

Coolant through index pin

Arrosage par le doigt d'indexage / Kühlmittelzufuhr durch bolzen

bar/psi max 12/175

High speed option RPM max



Haute vitesse en option RPM / Hochgeschwindigkeit optional UPM max

6.000

CAP 6 Slim design 90°

Technical Data

Caractéristiques techniques / Technische Daten

		ER-40A / 26 mm
R.P.M max	Heavy duty bearings	3.000
		16 kg
		1:1
KW		20 kW
Nm max		130 Nm
Rotation		in = out (A-C) in ≠ out (B)

L / H

Other measures under request

Autres mesures sur demande
Weitere Maßnahmen auf Anfrage

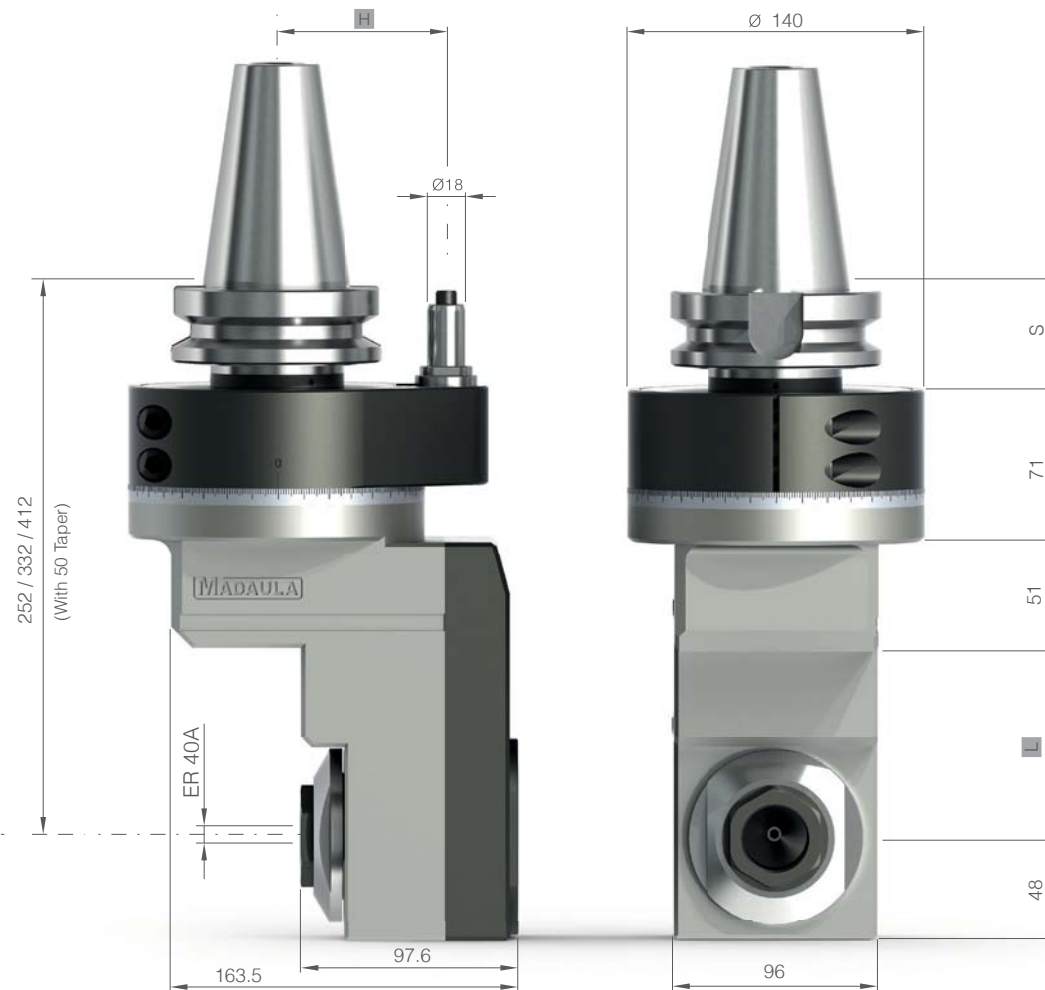
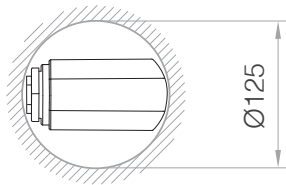

MADAULA
creative solutions

L	A	90
	B	170
	C	250

Taper	Size	H	S
Cône / Kegel	Taille / Größe		
DIN 69871 / 2080	50	80	40
CAT	50	80	40
MAS-BT	50	80	50
HSK	80/100	80	40/50
CAPTO	C8	80	50
KM	80/100	80	40/50

Standard Equipment

Standard / Standard

Optional Equipment

Optionel / Option

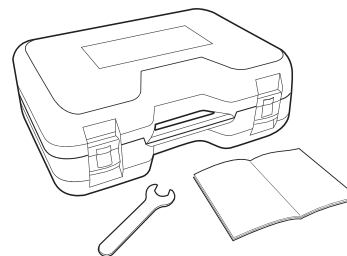

Stop Block

Bloc d'arrêt / Anschlag-Block

See page 55 

Collets

Pinces / Spannzangen

See page 56 

Coolant through index pin

Arrosage par le doigt d'indexage / Kühlmittelzufuhr durch bolzen

bar/psi max 12/175

High speed option RPM max

Haute vitesse en option RPM / Hochgeschwindigkeit optional UPM max

4.000

CAP

IC

COOLANT
Slim design

MADAULA

creative solutions

Technical Data

Caractéristiques techniques / Technische Daten

	CAP 4 IC	CAP 5 IC	CAP 6 IC
	ER-25A	ER-32A	ER-40A
R.P.M max	4.000	4.000	3.000
	14 kg	16 kg	18 kg
	1:1	1:1	1:1
KW	7 kW	16 kW	20 kW
Nm max	40 Nm	75 Nm	130 Nm
Rotation	in = out	in = out	in = out
Max. pressure	80 bar	80 bar	80 bar



Ø 97

Ø 111

Ø 125

Other measures under request. See page 46 to 48.

Autres mesures sur demande. Voir page 46 à 48.

Weitere Maßnahmen auf Anfrage. Siehe Seite 46 bis 48.

Always run wet

Tourner toujours avec arrosage / Nicht ohne Kühlmittel fahren

Filtration

Filtration / Filtration

40 µm

Always keep below the max. speed

Tourner toujours au dessous de la vitesse maxi /

Immer unter der maximalen Geschwindigkeit zu halten

Alternative outputs

Sorties alternatives / Alternative Ausgänge

See page 55

Internal Coolant

CAP 4 IC



CAP 5 IC

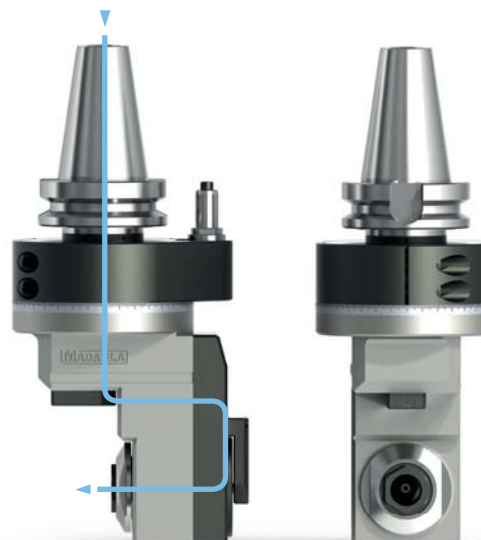

CAP 6 IC

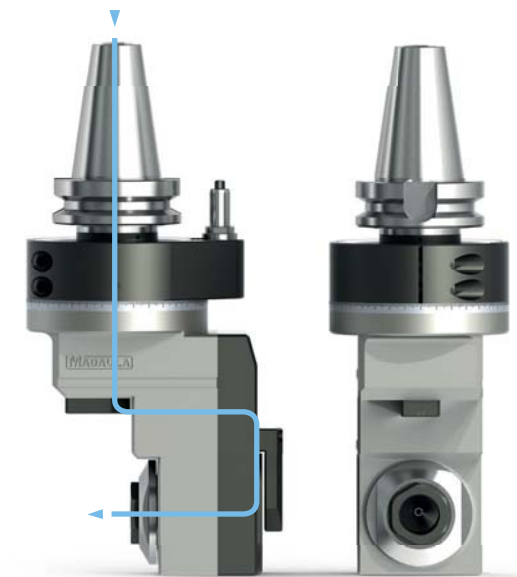



CAD

90°
Double output

MADAULA
creative solutions

Technical Data

Caractéristiques techniques / Technische Daten

	ER-25A / 16 mm
R.P.M max	5.000
	5.2 kg
	1:1
KW	3.5 kW
Nm max	14 Nm
Rotation	in ≠ out / in = out

L / H

Other measures under request

Autres mesures sur demande

Weitere Maßnahmen auf Anfrage

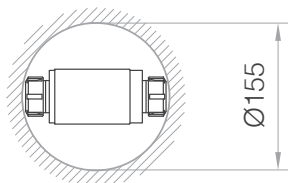

Taper Cône / Kegel	Size Taille / Größe	H	S
DIN 69871 / 2080	30/40/50	55/65/80	40
CAT	30/40/50	55/65/80	40
MAS-BT	30/40/50	55/65/80	40/40/50
HSK	50/63/100	55/65/80	40/40/50
CAPTO	C5/C6/C8	55/65/80	40/40/50
KM	50/63/100	55/65/80	40/40/50

Standard Equipment

Standard / Standard

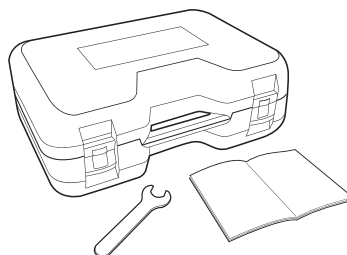

Optional Equipment

Optionel / Option

Stop Block

Bloc d'arrêt / Anschlag-Block

See page 55 

Collets

Pinces / Spannzangen

See page 56 

Coolant through index pin

Arrosage par le doigt d'indexage / Kühlmittelzufuhr durch bolzen

bar/psi max 12/175

High speed option RPM max

Haute vitesse en option RPM / Hochgeschwindigkeit optional UPM max

8.000

CAD

1 90° Double output

Technical Data

Caractéristiques techniques / Technische Daten

		ER-32 / 20 mm
R.P.M max	Heavy duty bearings	3.000
		8.7 kg
		1:1
KW		5 kW
Nm max		35 Nm
Rotation		in ≠ out / in = out

L / H

Other measures under request

Autres mesures sur demande

Weitere Maßnahmen auf Anfrage

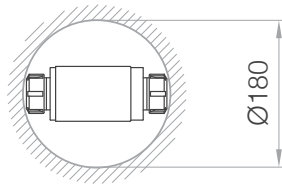

MADAULA

creative solutions

Taper	Size	H	S
Cône / Kegel	Taille / Größe		

DIN 69871 / 2080	40/50	65/80	40
CAT	40/50	65/80	40
MAS-BT	40/50	65/80	40/50
HSK	63/100	65/80	40/50
CAPTO	C6/C8	65/80	40/50
KM	63/100	65/80	40/50

Standard Equipment

Standard / Standard

Optional Equipment

Optionel / Option

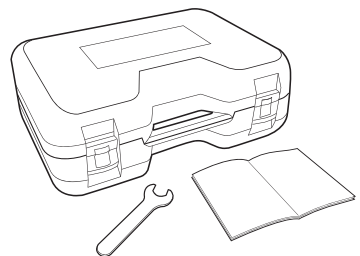

Stop Block

Bloc d'arrêt / Anschlag-Block

See page 55 

Collets

Pinces / Spannzangen

See page 56 

Coolant through index pin

Arrosage par le doigt d'indexage / Kühlmittelzufuhr durch bolzen

bar/psi max 12/175

High speed option RPM max

Haute vitesse en option RPM / Hochgeschwindigkeit optional UPM max



6.000

CAD

2 90° Double output

Technical Data

Caractéristiques techniques / Technische Daten

		ER-40 / 30 mm
R.P.M max	Heavy duty bearings	2.500
		13.5 kg
		1:1
KW		16 kW
Nm max		90 Nm
Rotation		in ≠ out / in = out

L / H

Other measures under request

Autres mesures sur demande

Weitere Maßnahmen auf Anfrage

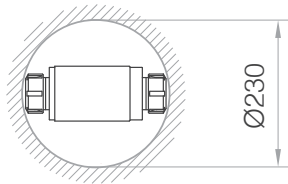

MADAULA

creative solutions

Taper Cône / Kegel	Size Taille / Größe	H	S
-----------------------	------------------------	---	---

DIN 69871 / 2080	50	80	40
CAT	50	80	40
MAS-BT	50	80	50
HSK	80/100	80	40/50
CAPTO	C8	80	50
KM	80/100	80	40/50

Standard Equipment

Standard / Standard

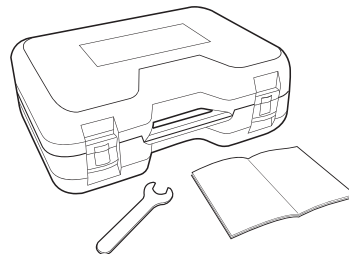

Optional Equipment

Optionel / Option

Stop Block

Bloc d'arrêt / Anschlag-Block

See page 55 

Collets

Pinces / Spannzangen

See page 56 

Coolant through index pin

Arrosage par le doigt d'indexage / Kühlmittelzufuhr durch bolzen

bar/psi max 12/175

High speed option RPM max

Haute vitesse en option RPM / Hochgeschwindigkeit optional UPM max

4.000

CAD

90° Double output

MADAULA
creative solutions

Technical Data

Caractéristiques techniques / Technische Daten

		ER-50 / 34 mm
R.P.M max	Heavy duty bearings	2.000
		24 kg
		1:1
KW		20 kW
Nm max		130 Nm
Rotation		in ≠ out / in = out

L / H

Other measures under request

Autres mesures sur demande

Weitere Maßnahmen auf Anfrage

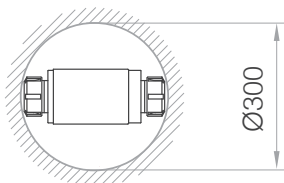

Taper	Size	H	S
Cône / Kegel	Taille / Größe		

DIN 69871 / 2080	50	80	40
CAT	50	80	40
MAS-BT	50	80	50
HSK	80/100	80	40/50
CAPTO	C8	80	50
KM	80/100	80	40/50

Standard Equipment

Standard / Standard

Optional Equipment

Optionel / Option

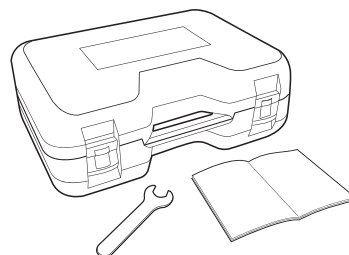

Stop Block

Bloc d'arrêt / Anschlag-Block

See page 55

Collets

Pinces / Spannzangen

See page 56

Coolant through index pin

Arrosage par le doigt d'indexage / Kühlmittelzufuhr durch bolzen

bar/psi max 12/175

High speed option RPM max

Haute vitesse en option RPM / Hochgeschwindigkeit optional UPM max

4.000

Flange mounted

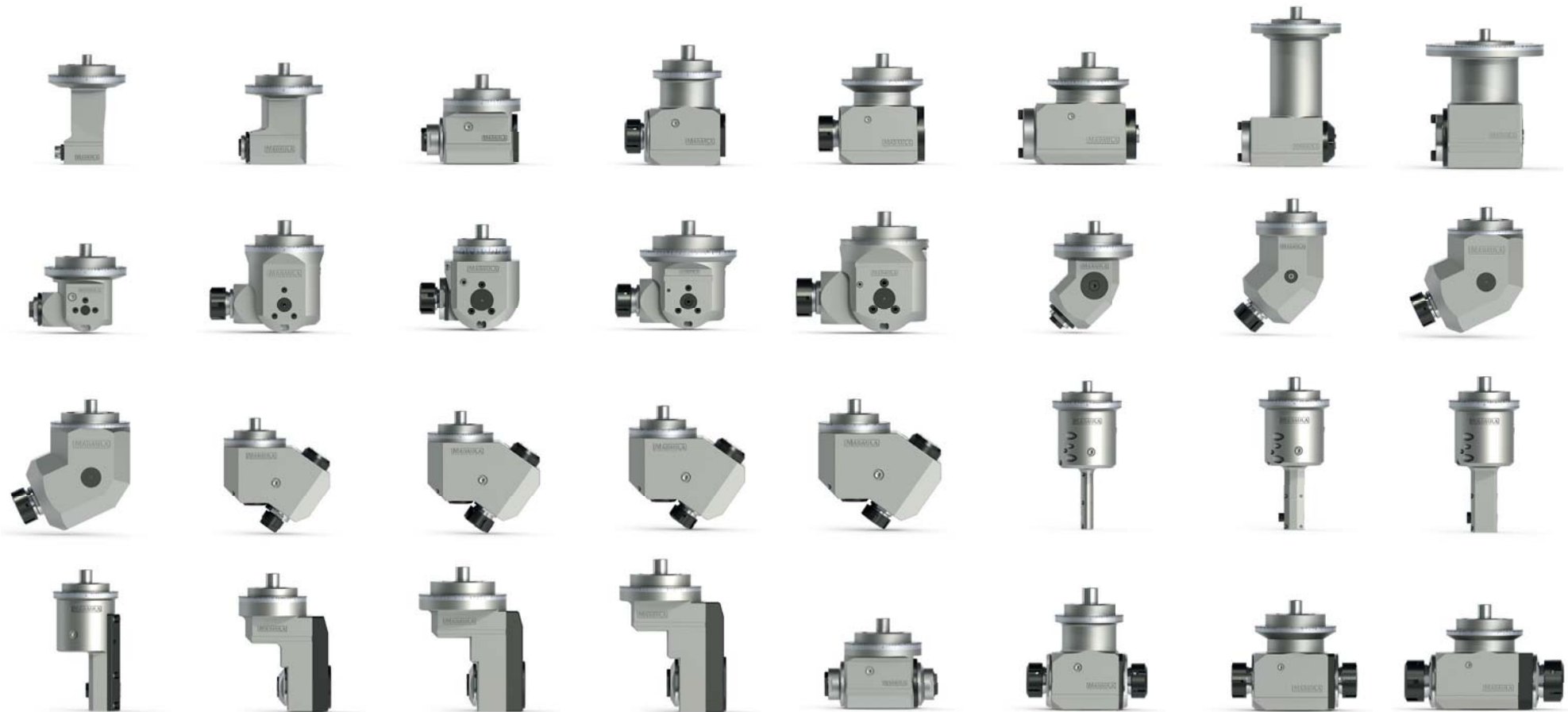

Heads for milling machines / machining units

All the heads our product range are also available to be assembled onto milling machines / machining units through flange.

This provides higher rigidity and easier 360° positioning around its axis.

Tous les renvois de la gamme, sont aussi disponibles pour son montage sur des fraiseuses/unités d'usinage moyennant une flasque adaptée.

Cela permet une extra rigidité et un positionnement angulaire très facile de 360° autour de son axe.

Alle Köpfe unserer Produktpalette sind auch auf Fräsmaschinen / Bearbeitungseinheiten durch Flansch montierbar.

Dies bietet eine höhere Steifigkeit und eine leichtere 360° - Positionierung um ihre Achse.

Output types

ER Collet DIN 6499

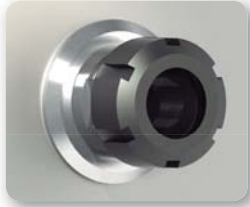

Coromant Capto®



ER-A Internal collet DIN 6499 / KM™



Quick change tapping holder / HSK DIN 69893



Weldon DIN 1835 or Wistle notch / ABS® KOMET®



Madaula modular MMT System / DIN 6358



Index arm types All types of indexation

Cylindrical
(Standard)



Conical



Flat faces



Special flange with 3 stabilization points system



Increased rigidity
Rigidité accrue
Erhöhte Festigkeit

Stop block Locking and unlocking device

- The stop block provides 3 basic benefits:
- Prevents the angle head rotation.
- Ensures the repeatability during automatic tool change.
- Ensures the positioning accuracy.

- Standard stop block:
- C45 Steel body
- Case hardened and ground bushing

- Other types available on request to fit all type of machines.

- Le Bloc d'arrêt a 3 fonctions:
- Éviter la rotation du renvoi.
- Assurer la répétabilité pendant changement automatique de l'outil.
- Assurer la précision de la position.

- Stop block standard:
- Corps en acier C45
- Cannon en acier cementé et trempé.

- Autres types sont disponibles pour moutage sur tous types de machines.

- Der Anschlag-Block liefert 3 grundlegende Vorteile:
- Er verhindert die Drehung des Winkelkopfes.
- Sorgt für die Wiederholgenauigkeit beim automatischen Werkzeugwechsel.
- Gewährleistet Positioniergenauigkeit.

- Standard- Anschlag-Block:
- C45 Stahlgehäuse
- Gehärtetes Gehäuse und Aufnahmebuchse.

- Andere Aufnahmen verfügbar, passend auf alle Maschinenausführungen.

Stop block must be ordered separately
Bloc d'arrêt doit être commandé séparément
Anschlag-Block muss separat bestellt werden



Collets

Standard



Tapping without compensation



Tapping ET-1 with compensation



Clamping nuts

Std



Mini (M)



Internal (A)



Sealed



Sealing discs

Standard sealing disc



Type	Standard			Tapping without compensation			Tapping ET-1 with compensation		Clamping nuts				Sealing discs			
	Order n°	Range Ø	Increment	Order n°	Range Ø	Increment	Order n°	Range Ø	Order n°	Order n°	Order n°	Order n°	Order n°	Range Ø	Increment	
ER-8	1108.XXX00	1-5	0.5													
ER-11	1111.XXX00	1-7	0.5	1411.XXX00	1-7	0.5	1516.XXX00	1.4-3.55	3411.00000	3511.00000	3311.00000	3411.2XXXX0 Ø Range 1-5				
ER-16	1116.XXX00	1-10	1	1416.XXX00	4-9	1	1516.XXX00	1.4-6.3	3416.00000	3516.00000	3316.00000	3416.20000	3916.0XXX0	3-10	0.5	
ER-20	1120.XXX00	1-13	1	1420.XXX00	4-12	1	1520.XXX00	2.2-7	3420.00000	3520.00000	3320.00000	3420.20000	3920.0XXX0	3-13	0.5	
ER-25	1125.XXX00	1-16	1	1425.XXX00	4-16	1	1525.XXX00	2.5-10	3425.00000	3525.00000	3325.00000	3425.20000	3925.0XXX0	3-16	0.5	
ER-32	1132.XXX00	2-20	1	1432.XXX00	4-20	1	1532.XXX00	4.5-12.5	3432.00000		3332.00000	3432.20000	3932.0XXX0	3-20	0.5	
ER-40	1140.XXX00	3-26	1	1440.XXX00	6-22	1	1540.XXX00	6-17	3440.00000		3340.00000	3440.20000	3940.0XXX0	3-26	0.5	
ER-50	1150.XXX00	10-34	2	1450.XXX00	22-32	3			3450.00000							

How to order. Example / Exemple comment commander / Wie man bestellt. Beispiel: ER-16 Standard collet / Range 3-2.5 = 1116.03000

NEW!

Angle Heads with Vibration drilling system (Patented)



Têtes Angulaires avec Système de perçage vibratoire / Winkelköpfen mit Schwingbohrsystem

Forced axial oscillations are superimposed on the drill feed for a controlled and regular chip breaking.

Des oscillations axiales forcées sont superposées au mouvement d'avance du foret pour une fragmentation maîtrisée des copeaux.

Erzwungene axiale Schwingungen werden für eine kontrollierte und regelmäßige Spanbruch auf dem Bohrvorschub überlagert.



Conventional drilling
Processus Conventioneel
Konventionelles Bohren



Vibratory drilling
Processus vibratoire
Vibrationsverfahren

Benefits*

- Conventional drilling
- Vibratory process

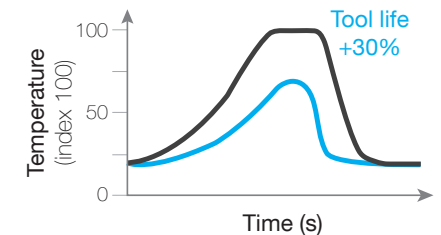
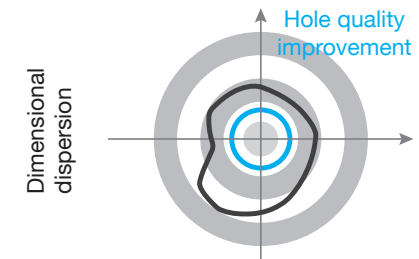
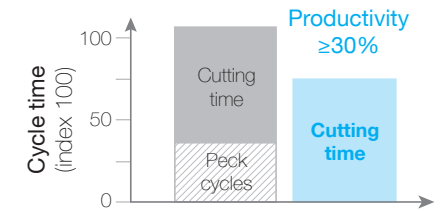

Main advantages



· Increased Productivity

- No more chip congestion
- Elimination of peck drilling cycles
- Increased cutting speed



· Tool cost control

- Increased tool life cycle
- Improved tool life prediction



· Optimized operations

- “One Shot” drilling
- Deep drilling - boring
- Reduction or even elimination of the lubrication



· Cost Savings

· Productivité accrue

- Fin des bourrages copeaux
- Suppression des cycles de “peck drilling”
- Augmentation des vitesses de coupe

· Maîtrise des coûts outils

- Augmentation des durées de vie
- Prédictivité accrue des durées de vie

· Opérations optimisées

- Perçage “One Shot”
- Perçage profond - forage
- Réduction / suppression de la lubrification

· Réduction de coûts

· Erhöhte Produktivität

- Keine Spänestau
- Beseitigung von picken Bohrzyklen
- Erhöhte Schnittgeschwindigkeit

· Kostenkontrolle

- Erhöhte Werkzeugstandzeitzyklus
- Verbesserte Standzeit-Vorhersage

· Optimierter Einsatz

- “One Shot” Bohren
- Tiefbohrung - Bohren
- Verminderung / Beseitigung der Schmierung

· Kosteneinsparung



In partnership with company
En partenariat avec la société
In Zusammenarbeit mit der Firma



FR-44340 Bouguenais

*Based on aerospace drilling operations

NC Automatic Rotary stop block (Patented)

NEW!

- 1 Allows machining in different angular positions around the Z axis.
Permetts travailler en différemts positions angulaires autour de l'axe Z.
Ermöglicht die Bearbeitung in verschiedenen Winkelpositionen um die Z-Achse.

- 2 Driven by machine spindle.
Rotation per la broche de la machine.
Antrieb durch die Spindel der Maschine.

- 3 Positioning ensured by the spindle of the machine encoder.
Précision de positionnement contrôlée par le codeur de la broche.
Positionierung durch den Encoder der Spindel der Maschine gesichert.

- 4 Allows automatic angle head change.
Permetts le changement automatique des outils.
Ermöglicht den automatischen Wechsel von Werkzeugen und Köpfen.

- 5 Suitable for any accessory such as angle head / multi-spindle head type.
Pour tout type de têtes à renvoi et autres dispositifs rotatifs.
Für alle Zubehörteile wie Winkelkopf / Mehrspindelkopf.

- 6 Available for any type of machining center (prior study).
Disponible pour tout type de CU, après étude.
Lieferbar für jede Art vom Bearbeitungszentrum (vorherige Studie).

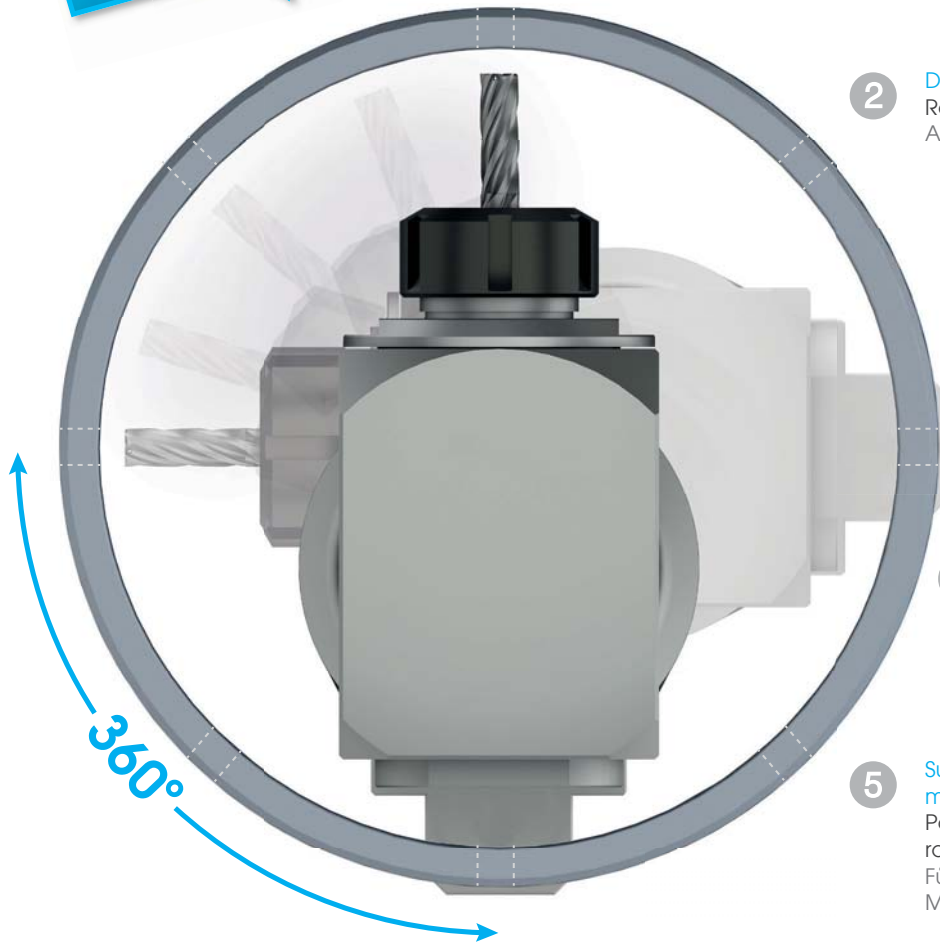

High Frequency Spindles for Machining centers



Automatic change

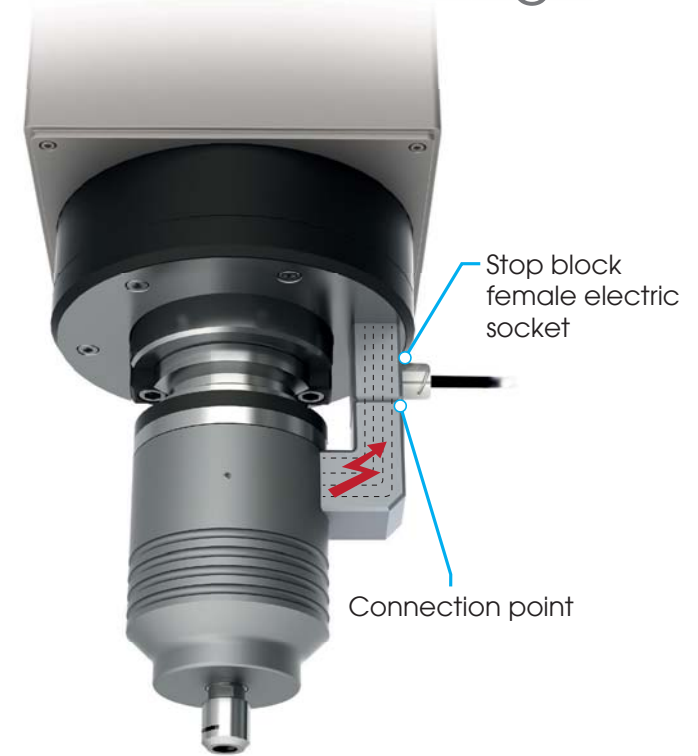

Equipment



Frequency converter



Power cord



Lubrication unit



UP Collets



Wrenches



Repair Service

Specialized repair team with extensive experience, at your disposal to overhaul all kind of high frequency spindles.

A votre service, une équipe spécialisée, expérimentée dans la remise en état de tous types de broches à hautes fréquences.

Spezialisiertes Reparaturteam mit langjähriger Erfahrung steht Ihnen für alle Arten von Hochfrequenzspindelindienst zur Verfügung.

Quality procedures

Progressive increasing to full speed

temperature, speed, noise, leakage and vibration control.

Accélération progressive jusqu'à la vitesse maximale, contrôle de température, vitesse, bruit, fuites et vibrations.

Progressive Aufzeichnung bis zur maximalen Geschwindigkeit: Temperatur, Geschwindigkeit, Lärm, Leckage- und Schwingungskontrolle.

100% Tested: main dimensional control

with Coordinate Measuring Machine for all products.

Contrôle des principales dimensions avec machine à mesurer CNC.

Hauptmaß-Kontrolle durch Koordinaten-Messmaschine für alle Produkte.

Quality certificate

on delivery.

Livraison du certificat de qualité.

Qualitätszertifikat bei Lieferung.



Certificate ISO 9001: 2015 since 1999

Certificat ISO 9001: 2015 depuis le 1999

Zertifikat ISO 9001: 2015 seit 1999

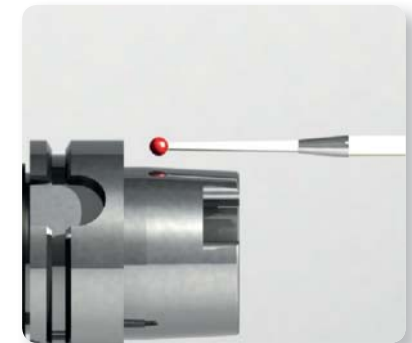

Precision

Maximum misalignment

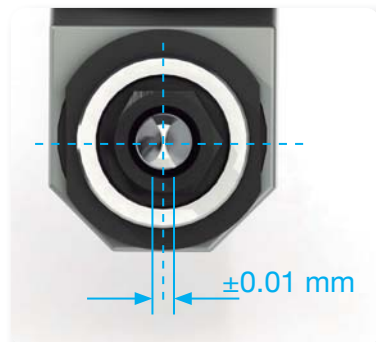

Angle tolerance

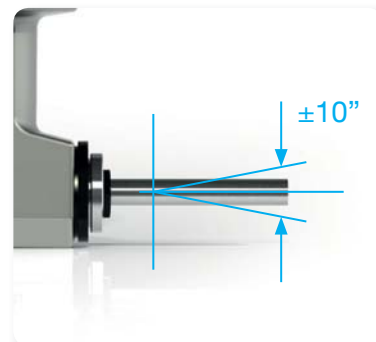

Max. runout inside the spindle

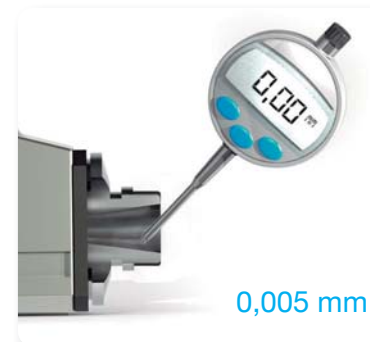

Global services



Specialized technical assistance team with extensive experience at your disposal.

Une équipe spécialisée en assistance technique et avec une vaste expérience est mis à votre disposition.

Das technisch spezialisierte Service Team mit langjähriger Erfahrung steht Ihnen gerne zur Verfügung.



Repair service

We are proud of offering to our customers a repair service for all their products, no matter how old they are.

All products of our fabrication range can be repaired, even if they have not been originally manufactured by Madaula.

Nous assurons pour nos clients un service réparation pour tous nos produits de notre marque ou de nos concurrents et de toutes générations.

Tous les produits de notre gamme de production peuvent être réparés, même s'ils n'ont pas de notre fabrication.

Wir sind stolz darauf, unseren Kunden unser Reparatur-Service für alle ihre Produkte anzubieten, egal wie alt sie sind.

Alle Produkte unserer Fertigungspalette können repariert werden, auch wenn sie nicht ursprünglich von Madaula hergestellt wurden.



EXPRESS service

Express repair service on demand.
Repair of worn or damaged parts.
Reduction of downtimes.

Réparation express sur demande.
Réparation des éléments abimés ou cassés en minimisant les temps d'arrêt.

Express-Reparatur-Service auf Anfrage.
Reparatur verschlissener bzw beschädigter Teile.
Vermindern Sie Ausfallzeiten.

Preventive maintenance

Process efficiency optimization through our preventive maintenance plan.

Nous optimisons l'efficacité du processus grâce à notre plan de maintenance préventive.

Optimieren Sie die Prozesseffizienz durch unseren präventiven Wartungsplan.



Everything is possible

Customized products for Innovative solutions: We match the tool to the part and to the machine.

Our team of engineers and technicians are working together to create new products to enhance the machine capabilities and increase the productivity of our customers.

55 years of experience

in the development of special products.

55 ans d'expérience dans le développement de produits spéciaux.

55 Jahre Erfahrung in der Entwicklung von Sonderlösungen.

Successful technical experience

and market knowledge.

Réussi savoir-faire technique et connaissance du marché.

Erfolgreiche technische Erfahrungen und Marktkenntnisse.

Engineers and technicians

working to together.

Ingénieurs et techniciens qui travaillent ensemble.

Ingenieure und Techniker arbeiten Hand in Hand.

Ingenuity and open mind

to find the best solutions.

Ingéniosité et l'esprit ouvert pour trouver les meilleures solutions.

Einfallsreichtum und Aufgeschlossenheit, um stets die besten Lösungen zu finden.



Continuous innovation: We ensure close cooperation with our customers worldwide.



Innovation non-stop:

Nous assurons une étroite coopération avec nos clients dans le monde entier.

Stetige Innovationen:

Wir sorgen weltweit für eine enge Zusammenarbeit mit unseren Kunden.

Special products

Design and production according to the customer specifications. More than 8000 special designed and manufactured heads as per our customer's requirements.

Conception et fabrication selon les spécifications des clients. Plus de 8000 types spéciaux fabriqués.

Gestaltung und Produktion gemäß den Kundenvorgaben. More than 8000 specials designed and manufactured per our customer's requirements.



Star shaped
3 outputs



Cutter on axis with
steady holder



Very narrow room for
Aerospace industry



Reversed angle



Double parallel output



ISO 50 / ISO 50



HSK-63A adjustable angle



L = 250



With rotary center



Milling inside groove



Automatic tool change



Double milling output



Very narrow spaces



For composites
with vacuum system



X = 125 mm Offset
with internal coolant



CA-4 with flange



HSK-100A
Milling head



CA-1 with pick-up



L = 315
with 3 point



High press coolant HR



Aerospace application



High press. coolant



L = 300



CAD-2 L = 425

Wide range of solutions



Spindle speeders



Multispindle heads



High frequency spindles



Live tooling for CNC lathes



Live tooling for swiss type lathes



Heads & accessories