



**WITH YOU
SUCCESS TOGETHER**



VBX SERIES

Vertical Machining Center (Box way)



FEELER FAIR FRIEND GROUP
FAIR FRIEND ENTERPRISE CO., LTD.

HEADQUARTERS
No. 186, Yong Chi Road, Taipei, Taiwan.
Tel: +886-2-2763-9696
Fax: +886-2-2768-0636/37/39
www.ffg-tw.com
E-mail: chairom@fairfriend.com.tw

FEELER MACHINE TOOLS DIVISION
No. 12, Jingke Rd., Nantun Dist., Taichung, Taiwan
Tel: +886-4-2359-4075
Fax: +886-4-2359-4873
www.feeler.com
E-mail: sales@feeler.com



Website



Facebook

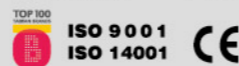

21.03.1000-S601000001

Three Axes Used Box Way

Perfect combination of
efficiency and stability

In response to heavy duty, general machining, and parts processing industries, FEELER provides the VBX series. Its high rigidity and high stability box way machining center has a stable structure. The three-axis is designed with a large span box way, and the heavy duty ability is excellent which present an extraordinary machining efficiency.



VBX-1100



VBX-1300

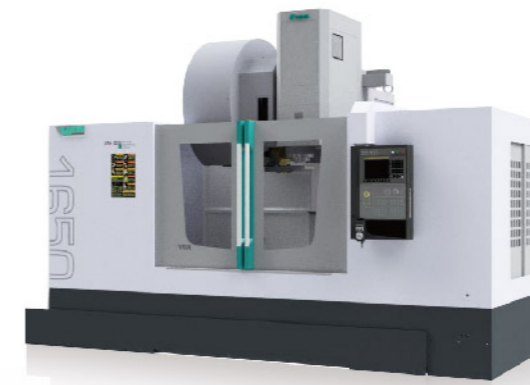

VBX-1400/1650



VBX-1900/2200

VBX SERIES

- The main body structure is made of Meehanite cast iron which the material is very stable, so the entire machine will not deform for a long life time.
- Three-axis ultra-wide box way rail, which greatly improves the rigidity and stability of the whole machine.
- The hard track is hardened by heat treatment and precision ground; the slideway surface is covered with Turcite-B, which has great wear resistance and ensures long-term accuracy.
- Three-axis ballscrew bearing is lubricated with oil to improve bearing life.
- Finite element analysis (FEM) software for dynamic simulation and structural analysis to ensure the machine achieves the best structural rigidity, machine accuracy and reliability.

Steady Mechanical Structure

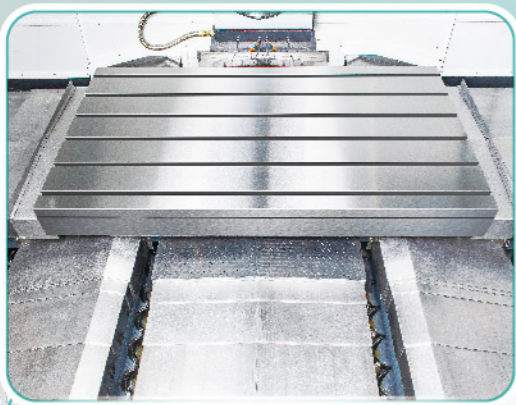
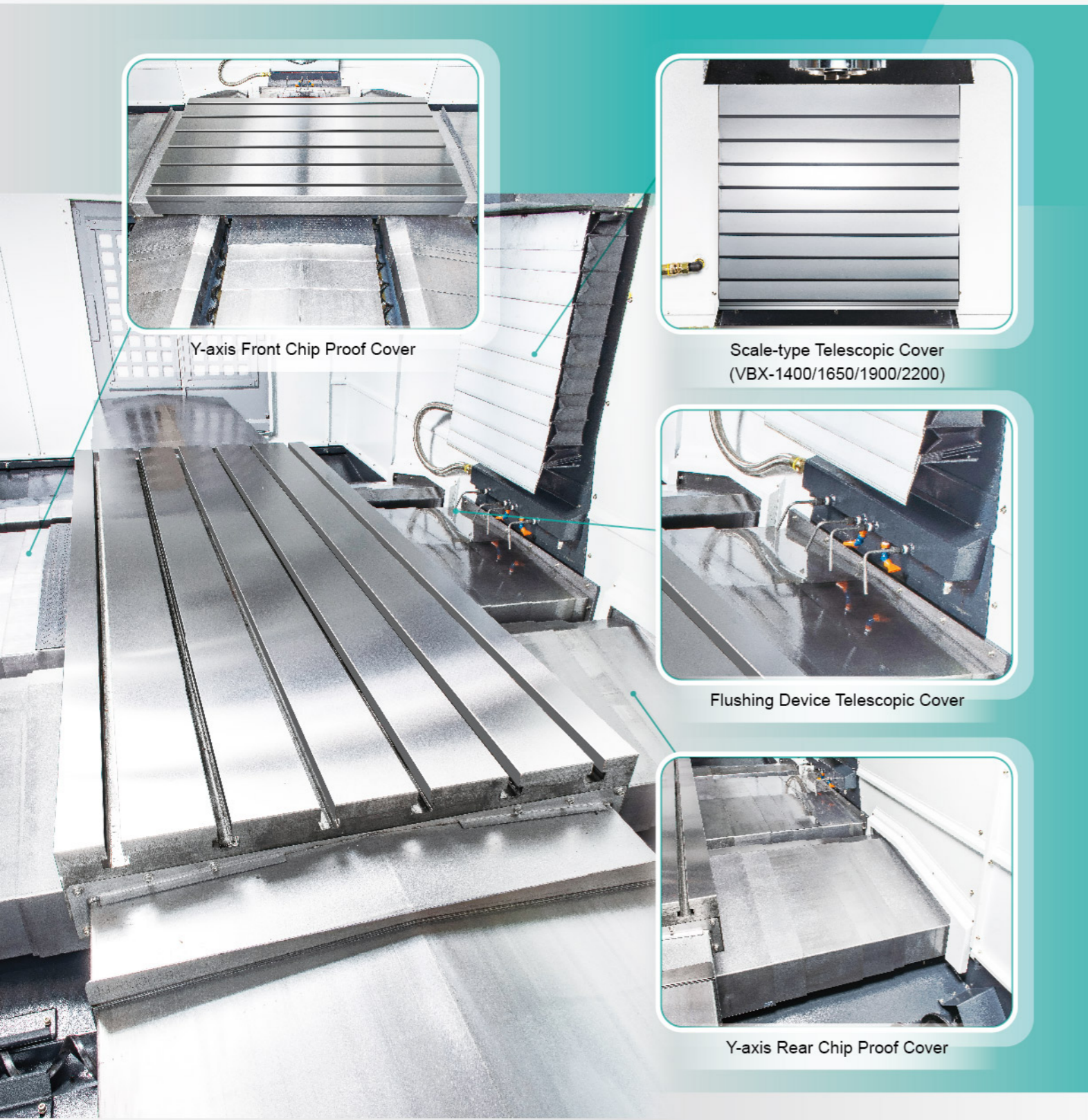

Y-axis Front Chip Proof Cover



Scale-type Telescopic Cover
(VBX-1400/1650/1900/2200)

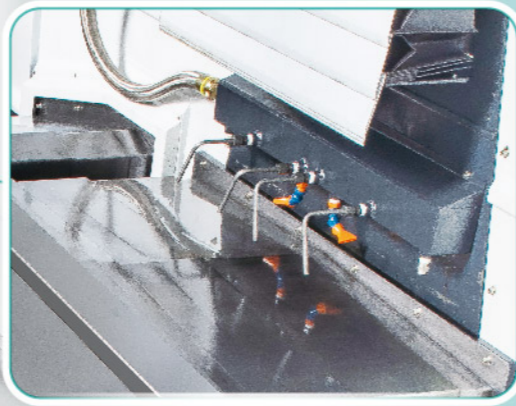

Flushing Device Telescopic Cover

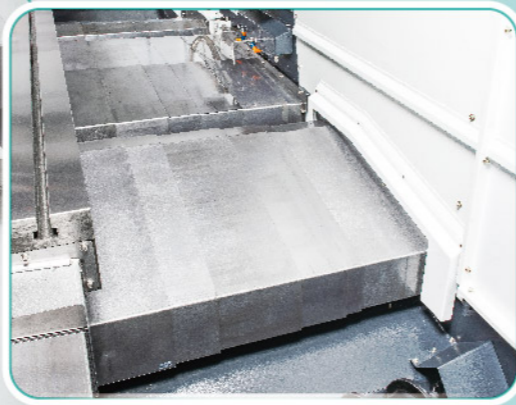

Y-axis Rear Chip Proof Cover



Belt Type Spindle :
Easy for assembling
and maintenance.



Gear Type Main Shaft :
Able to sustain low speed and high
torque load, suitable for low speed
and large deep machining.

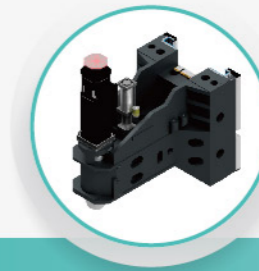

Direct-drive Spindle (DDS) :
Low transmission power loss, low-speed heavy
machining will not have belt-type tripping problems,
suitable for high-speed light machining.

Specially designed "A"-shaped
column bottom, strengthened
design, effectively improve
mechanical rigidity.

Worktable is capable for
heavy loading :
VBX-1100/1300 : 1300KG
VBX-1400 : 1500KG
VBX-1650 : 1800KG
VBX-1900 : 2200KG
VBX-2200 : 2700KG



High Precision Ball Screw :
X, Y, and Z axes are equipped
with precision ball screws,
which are pre-load to ensure
the best accuracy and
minimize the positioning error.

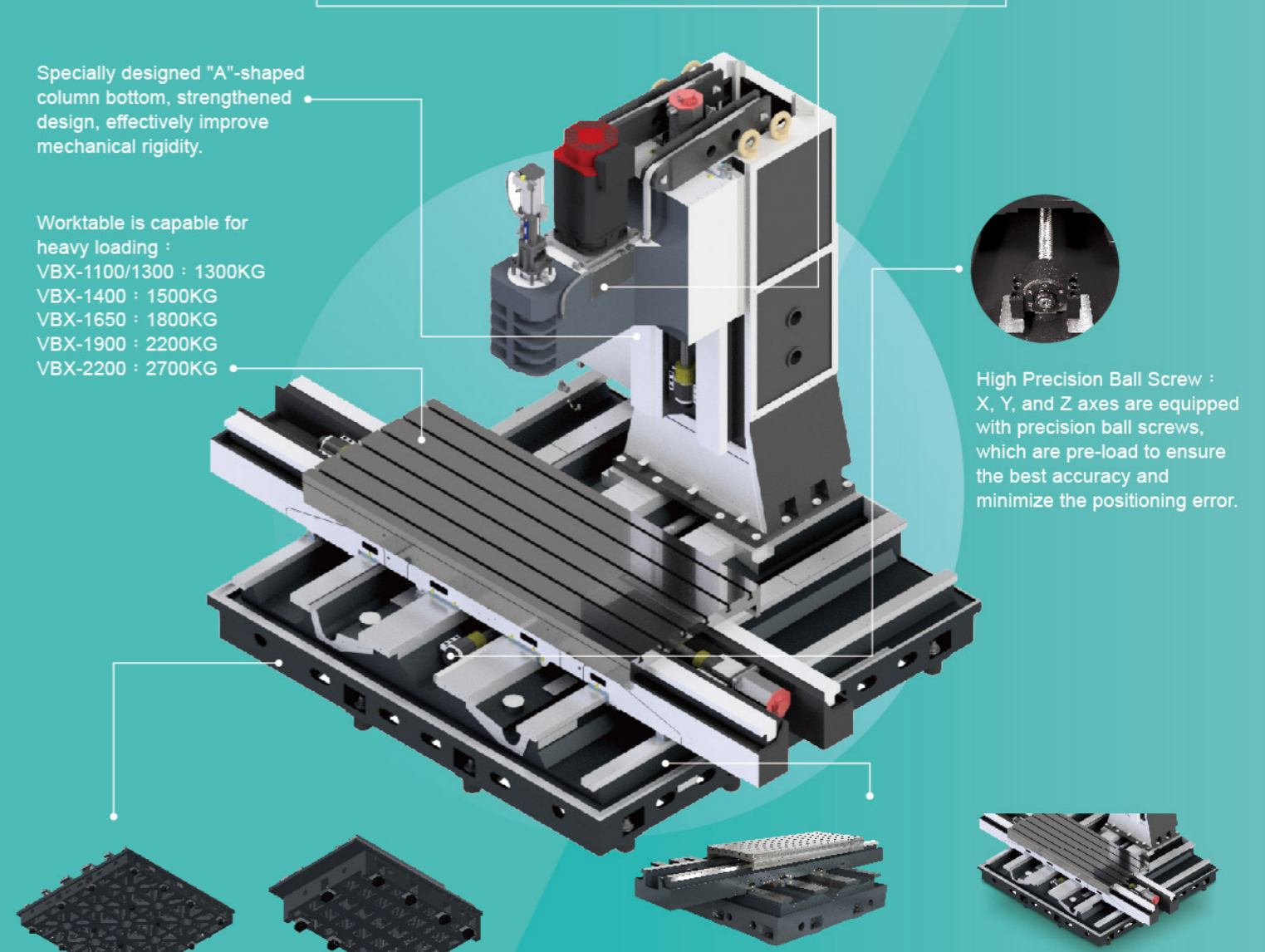

The base adopts a rigid design, which is resistant for
bending and torsion, thereby increasing the rigidity.

VBX-1100/1300/1400/1650/1900
Four Box Ways Base

The Y-axis stroke adopts four slide rails to
support, which is suitable for heavy loading.
Its structure is highly rigid and stable support.

VB-2200 - Six Box Ways Base
Specially designed six box ways
base structure for heavy load
support, which is extremely stable.

Machine Features

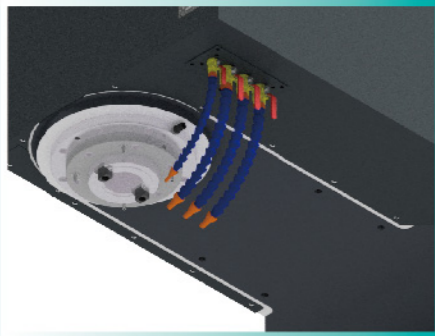

Spindle Coolant Nozzle

Powerful coolant flushing to remove metal chips with concentrated coolant. It helps to ensure accurate machining and to cool the cutting tool sufficiently which extends the service life of the cutting tool.



- Three-axis telescopic cover prevents chips and coolant from damaging the guide rail surface, ensuring machining accuracy and guide rail life.

Coolant Tank

Two removable filter box design, the filter is needed for alternately cleaning which prevents the pump from impurities of cutting fluid, effectively improving the pump life.

Two Channel Removable Filter Box Design

Cleaning Tools (rake)

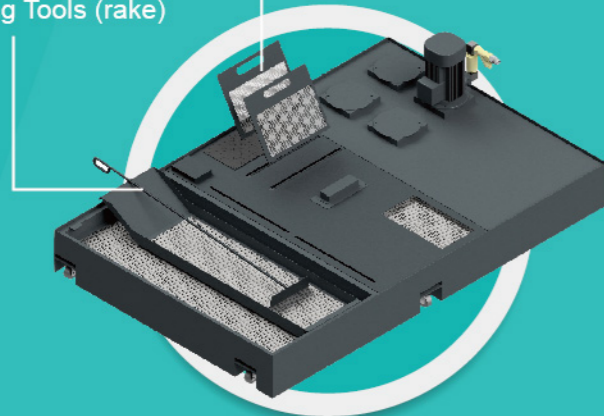

VBX- 1100 / 1300

Removable Filter

Cleaning Tools (rake)

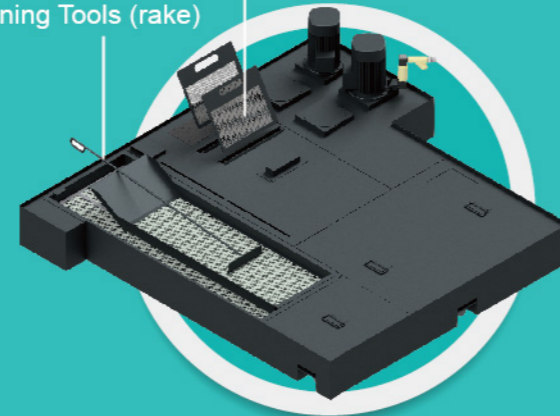

VBX-1400/1650

Removable Filter

Cleaning Tools (rake)

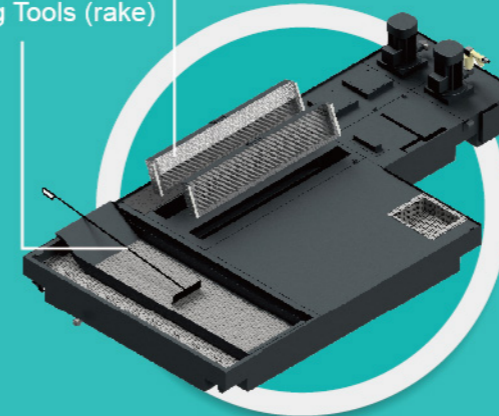

VBX-1900 / 2200



Dust-proof Electrical Cabinet

The electrical cabinet is dust proof. All wire through-holes are protected by water-resistant fittings to prevent oil moisture from entering. This extends the electronic part's service life and assures maximum reliability.

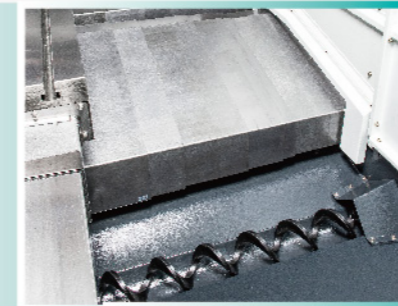

Chip Screws

Remove metal chip more quickly and efficiently.
(VBX-1400/1650/1900/2200 Standard)
(VBX-1100/1300 OPT.)

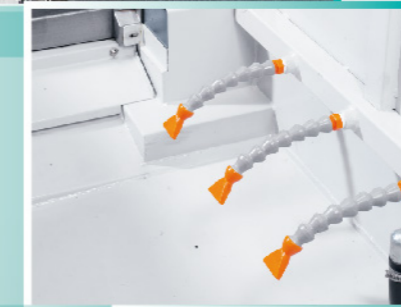

Coolant Flushing (OPT.)

Powerful flushing system can quickly and efficiently remove metal chips.



Air Gun and Coolant Gun Interface

The air gun and water gun connector are reserved for future usage.
▲ Air Gun(Standard) \` Coolant Gun (OPT.)

Gear Drive Transmission (OPT.)

Outstanding Features, Displaying Extraordinary Performance

Features of Gear Drive Spindle

- The spindle transmission is transmitted by gear, which upgrades rigidity and stability for heavy duty cutting.
- Two stage speed switch: Low speed / High torque (heavy duty cutting) High speed / Good for finish accurate cutting.

Coolant through spindle with floating unclamp mechanism eliminates bearing's Axial loading, thus increase spindle durability and accuracy.

Parallel axial centerline deployment, reinforces machining accuracy.

The head stock features box-structure with inner ribs enforcement, upgrades rigidity and stability for heavy duty cutting.

Direct transmission between moto and gear that delivers optimum power to the spindle.

Short Spindle nose increases rigidity, which reduces overhanging distance and increases cutting capabilities.

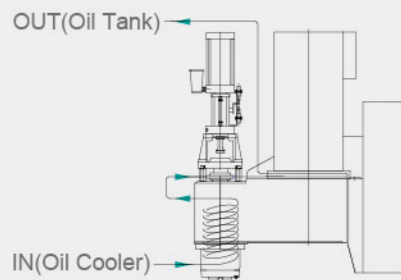
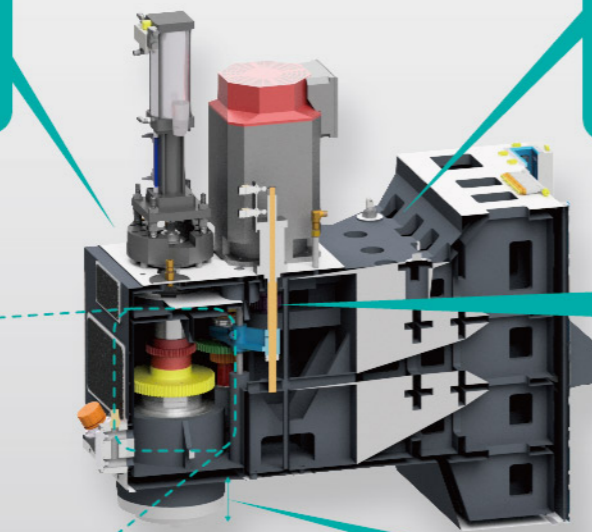

Spindle Cooling Device

The oil from the spindle cooling unit is particularly circulated around the spindle cartridge and spindle motor to maintain optimum running temperature to eliminate thermal expansion, and to prolong bearing life.

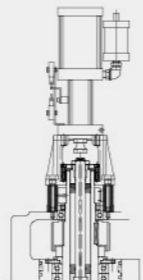

Floating Unclamp Mechanism

Eliminates bearing's axial loading and increase spindle durability.

Gear Drive Transmission (OPT.) Spindle Speed & Power Output Diagram

GEAR BOX

VBX-1100/1300/1400/1650/1900/2200

FANUC αi115 for spindle 6000rpm #50(1:4)

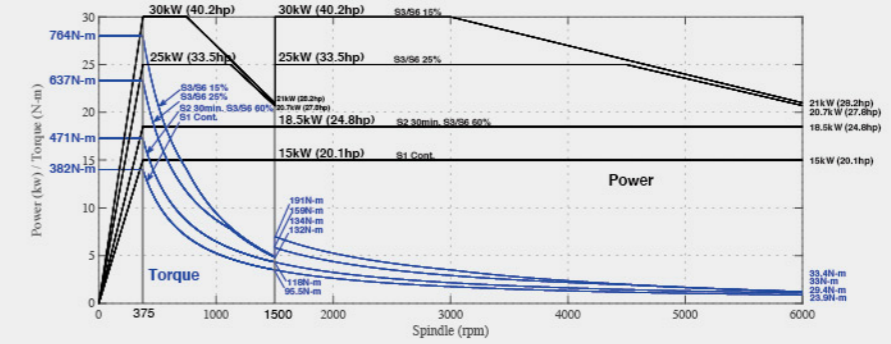

GEAR HEAD

VBX-1100/1300

FANUC αi115 for spindle 8000rpm #50 dia 85mm

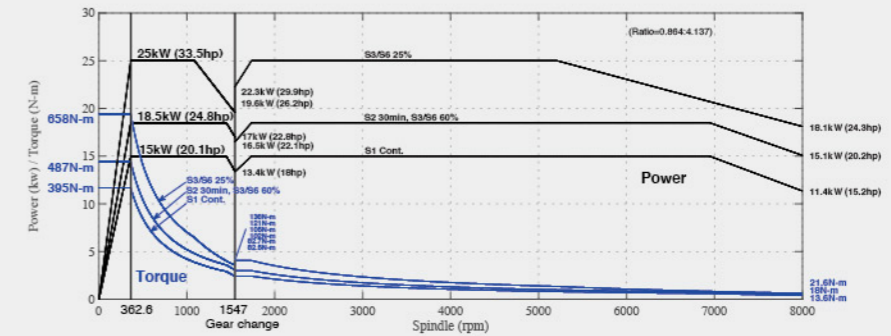

VBX-1400/1650/1900/2200

FANUC αi118 for spindle 6000rpm #50

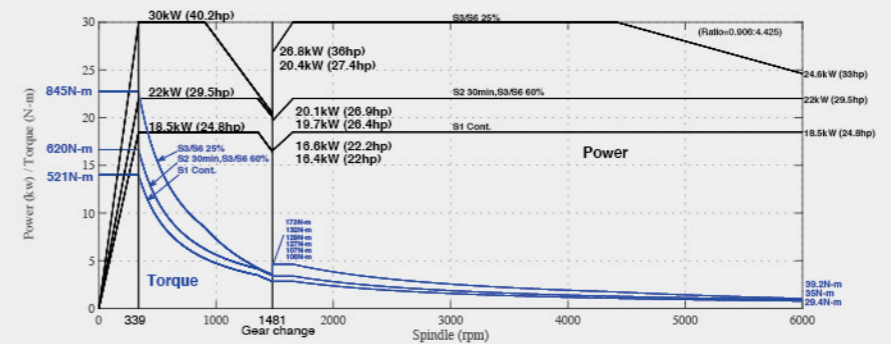

A Good Partner of Production

FEELER INTELLIGENCE MONITORING (OPT.)

Thermal Compensation

After long term operation and workpiece machining, it would cause thermal deformation of machine structure to affect accuracy. According to the information of temperature changing, which are located in machine structure (around 4~8 locations) and 8 channels Thermal compensation system, which is developed by Feeler R&D team to calculate the differences of temperature to do thermal compensation. Hence, the machining deviation accuracy will be restrained under 0.02mm to increase machining quality.

Features

- Establish independent temperature rise and thermal displacement compensation technology
- Self-developed 8-channel thermal compensation card
- Solve the problem of thermal displacement of machines
- Thermal deviation can be controlled within 0.02mm

Existing Cases

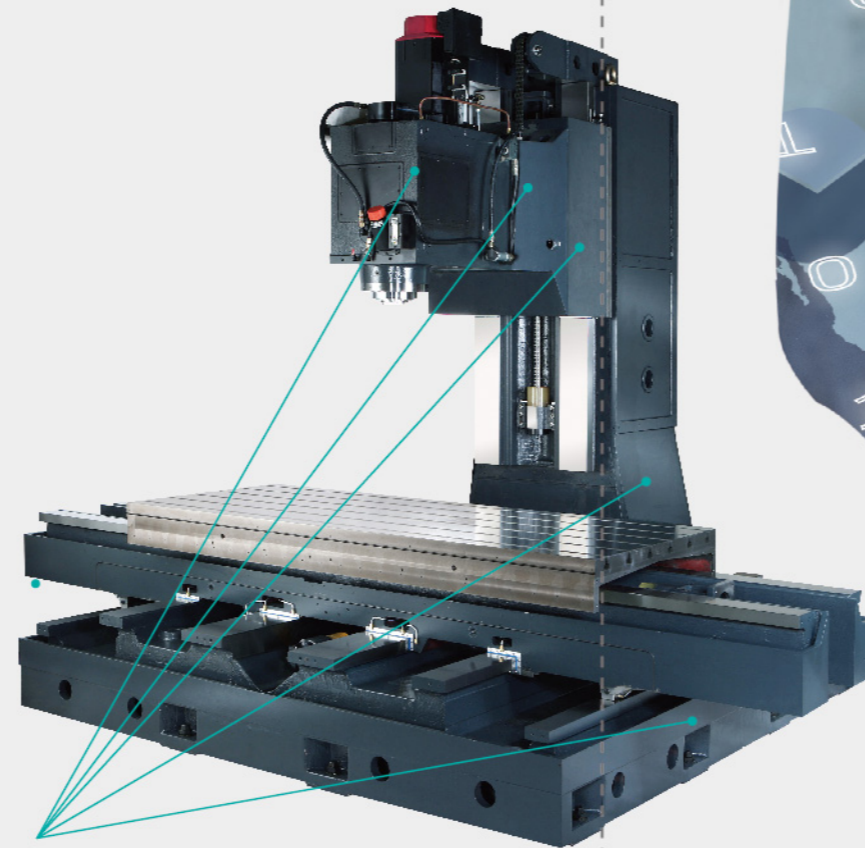
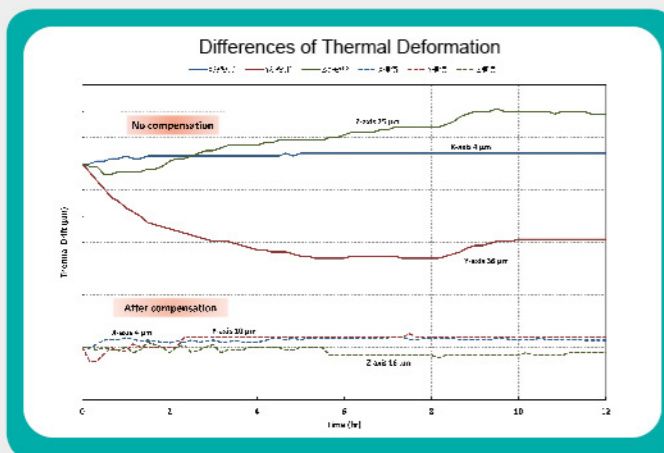

Temperature Sensor Place(sample)



POPULAR MODEL

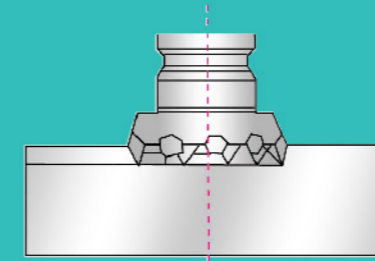

Face Milling S45C

Removal Rate **418 cc/min**

Tool	mm	Ø 125 x 6T
Spindle Speed	mm	1500 rpm
Feed rate	mm	1045 mm/min
Cutting Width *Depth	mm	80 *5 mm

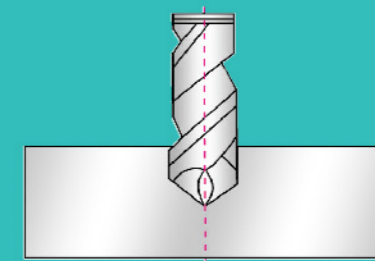

Drilling S45C

Tool Diameter **40 mm**

Tool	mm	Ø 40
Spindle Speed	mm	796 rpm
Feed rate	mm	120 mm/min
Cutting Depth	mm	60 mm

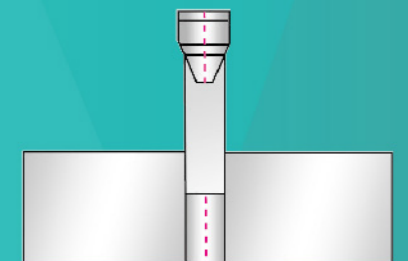

Tapping S45C

Tapping **M30**

Tool	mm	M30 x P3.5
Spindle Speed	mm	100 rpm
Feed rate	mm	350 mm/min
Cutting Depth	mm	45 mm

VBX-1300 / Belt Type 8000 rpm / Motor α i15(15/18.5kw)

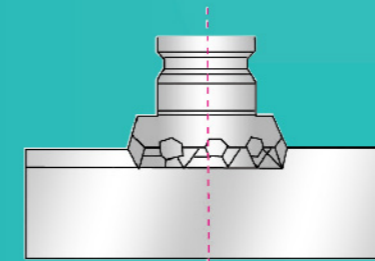

Face Milling S45C

Removal Rate **750 cc/min**

Tool	mm	Ø 125 x 8T
Spindle Speed	mm	375 rpm
Feed rate	mm	1500 mm/min
Cutting Width *Depth	mm	100 *5 mm

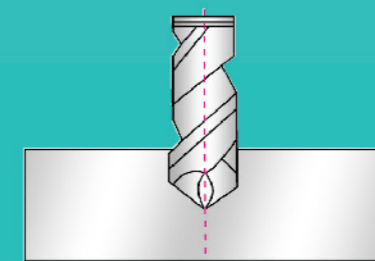

Drilling S45C

Tool Diameter **68 mm**

Tool	mm	Ø 68
Spindle Speed	mm	400 rpm
Feed rate	mm	60 mm/min
Cutting Depth	mm	95 mm

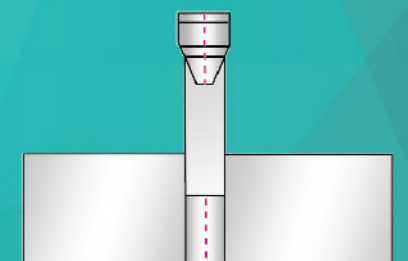

Tapping S45C

Tapping **M42**

Tool	mm	M42 x P4.5
Spindle Speed	mm	60 rpm
Feed rate	mm	270 mm/min
Cutting Depth	mm	75 mm

VBX-1650 / Gear Type 6000rpm/ Motor α i18(18.5/22kw)

Engineering Analysis

- **Model Chosen**

Based on workpiece to choose high C/P value and good efficiency machine model to meet processing requirements.

- **Engineering Analysis**

Assisting to do cycle time, tooling and fixture evaluation.

- **Automation/Turn-key Project**

Assisting automation /Turn-key project evaluation and engineering application.

Machine Layout/Working Table Dimensions

VBX-1100

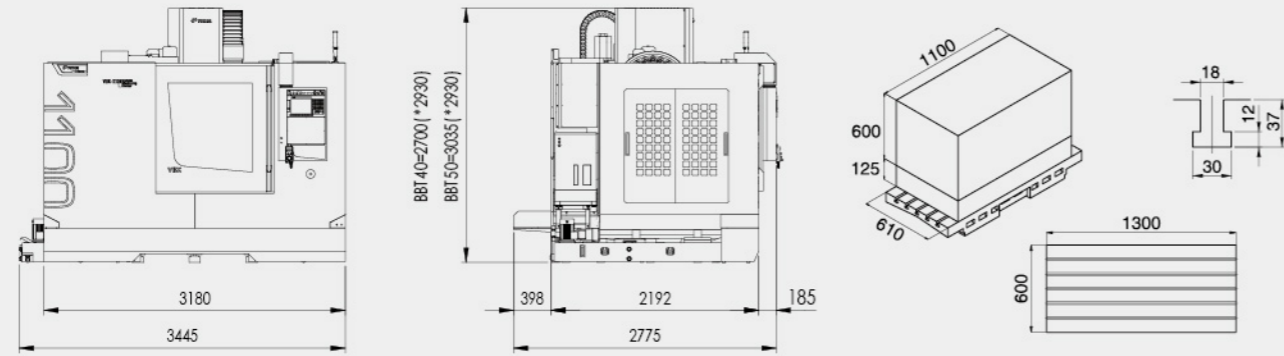

VBX-1300

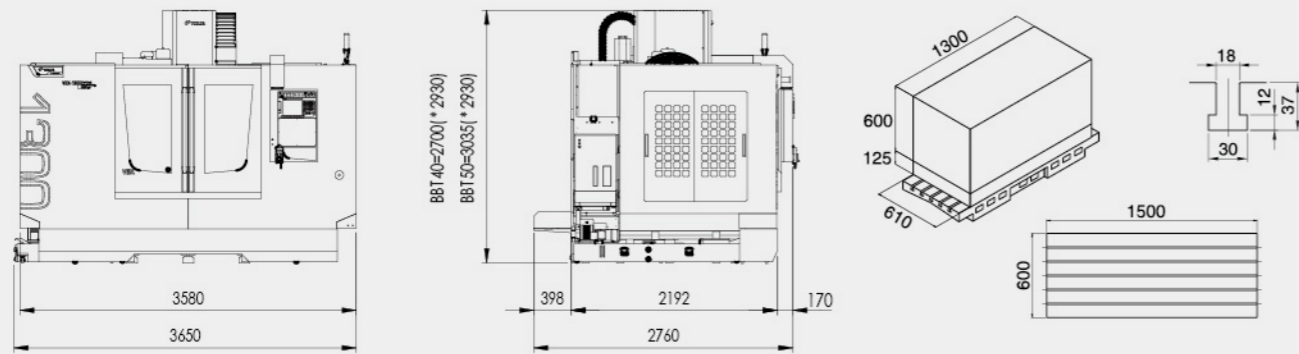

VBX-1400

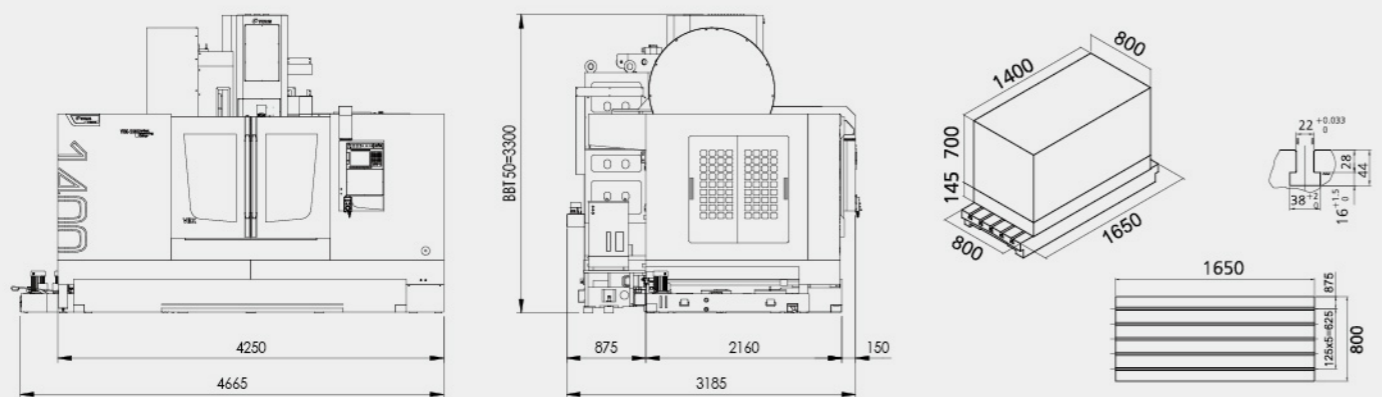

VBX-1650

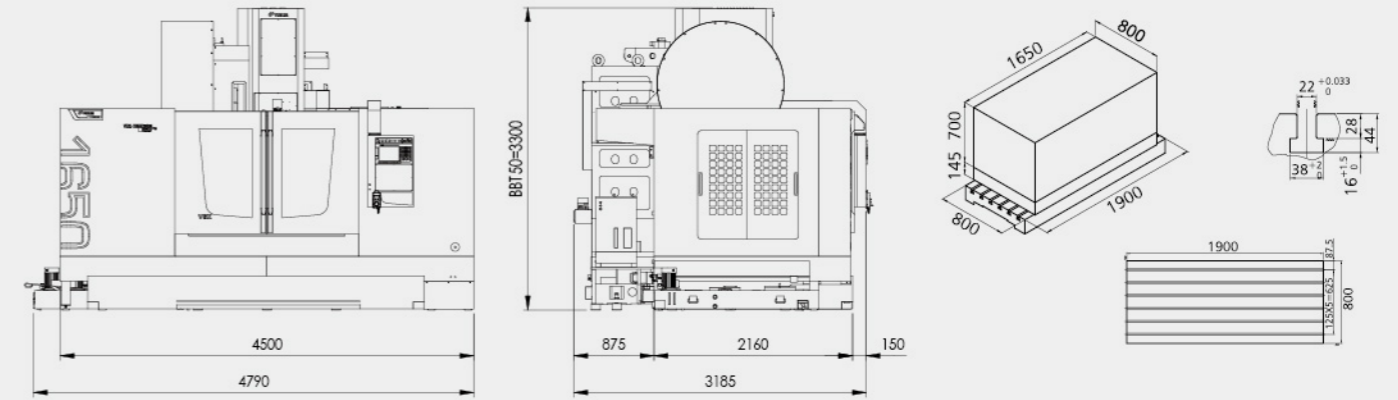

VBX-1900

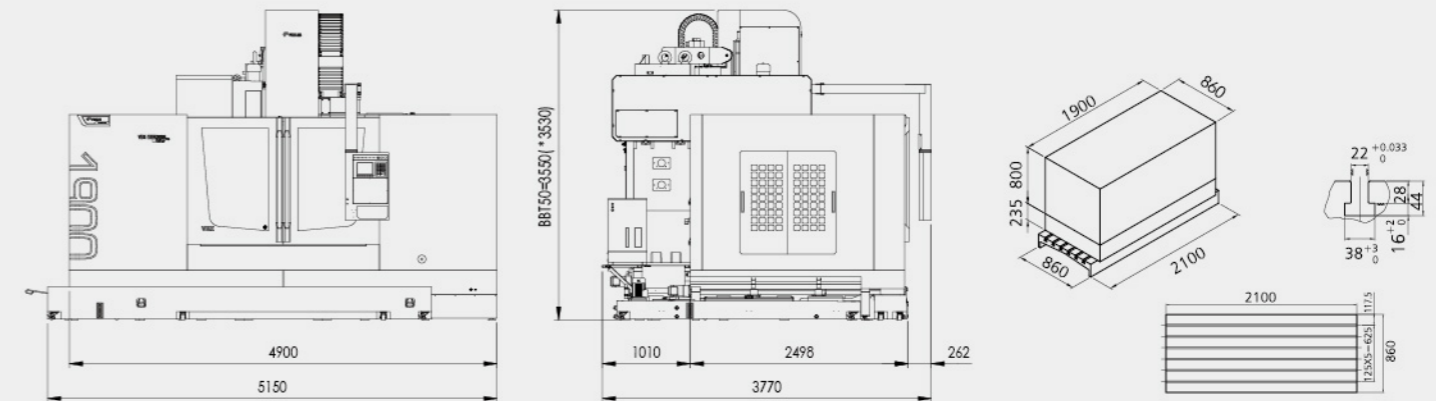

VBX-2200

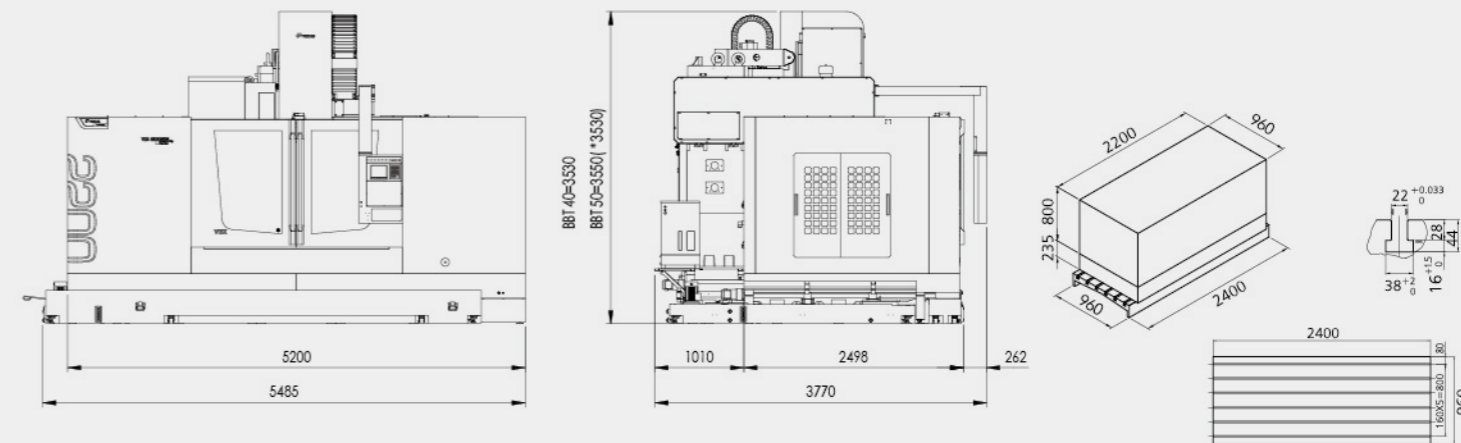

VBX SERIES

Spindle Torque/Motor Drawing

VBX-1100/1300_Belt Type

FANUC ai18 for spindle
10000rpm #40

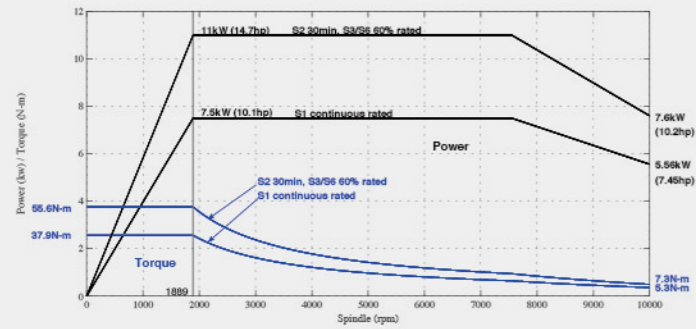

FANUC ai15 for spindle
10000rpm #40(OPT.)

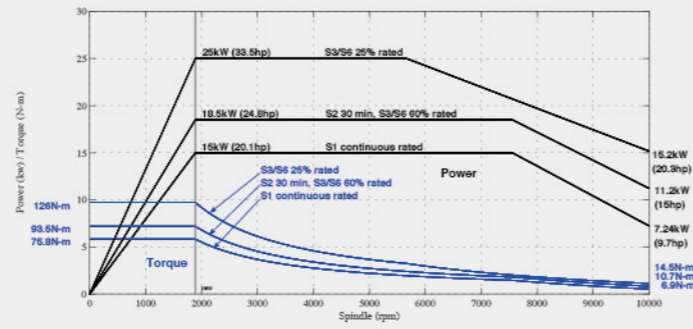

HEIDENHAIN QAN200L for spindle
10000rpm #40

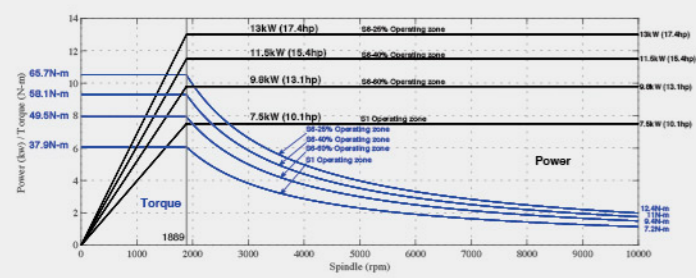

HEIDENHAIN QAN260M for spindle
10000rpm #40(OPT.)

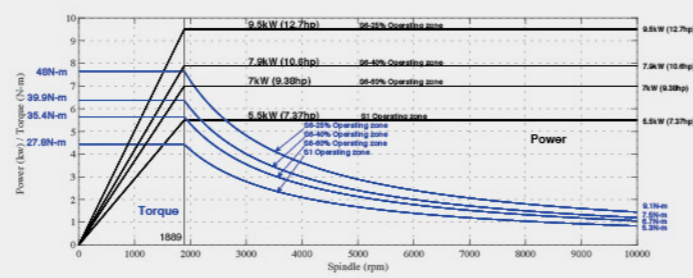

VBX-1400/1650_Belt Type

FANUC ai22 for spindle
4000rpm #50

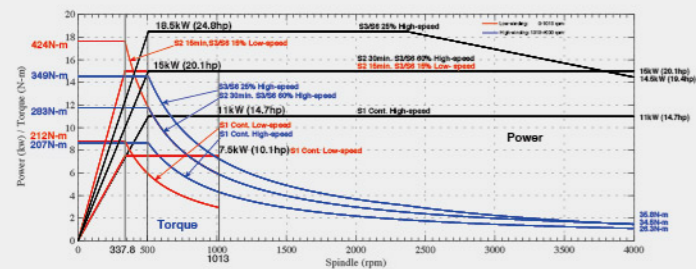

FANUC ai22 for spindle
8000rpm #40(OPT.)

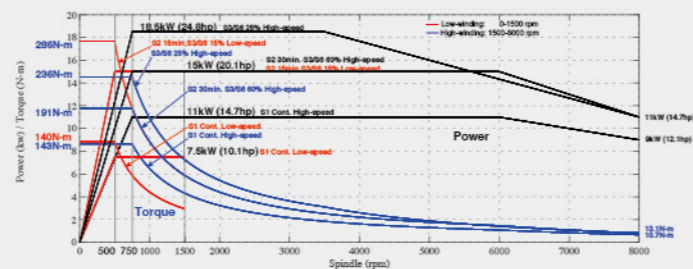

VBX-1900/2200_Belt Type

FANUC ai30 for spindle
4000rpm #50

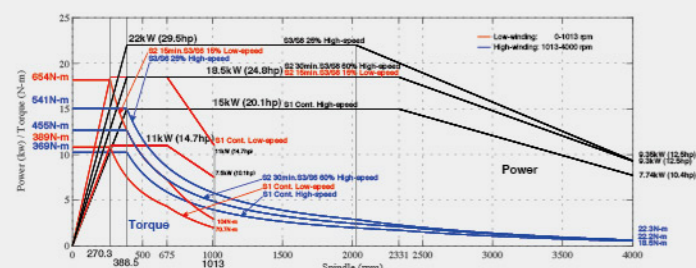

HEIDENHAIN QAN260L for spindle
12000rpm #40(OPT.) (for 2200)

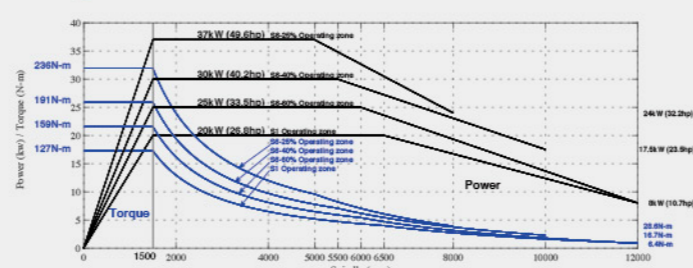

Machine Accessories

NO	ITEM	VBX-1100	VBX-1300	VBX-1400	VBX-1650	VBX-1900	VBX-2200
1	High Torque Wide-Range Spindle Motor(for Fanuc Controller Only)	●	●	●	●	●	●
2	Pretensioned 3-Axis Ball Screws	●	●	●	●	●	●
3	Automatic Lubrication System	●	●	●	●	●	●
4	Spindle Air Sealing	●	●	●	●	●	●
5	Spindle Coolant Nozzle	●	●	●	●	●	●
6	Spindle Air Blast	●	●	●	●	●	●
7	Spindle Oil Cooler	●	●	●	●	●	●
8	Dust-Proof Electrical Cabinet	●	●	●	●	●	●
9	Heat Exchanger for Electrical Cabinet	●	●	●	●	●	●
10	Air Condition for Electrical Cabinet	○	○	○	○	○	○
11	Leveling Bolts and Plates	●	●	●	●	●	●
12	Enclosed Splash Guard	●	●	●	●	●	●
13	Operation and Maintenance Manual	●	●	●	●	●	●
14	Belt-Drive Spindle 6,000 / 8,000rpm (No.50)	○	○	○	○	○	○
15	Belt-Drive Spindle 10,000 / 12,000rpm(No.40)	○	○	○	○	N/A	○
16	DDS Spindle 12,000 / 15,000rpm(No.40)	○	○	○	○	○	○
17	Gear Box-Drive Spindle –Spindle Speed 6,000rpm(No.50)	○	○	○	○	○	○
18	Gear Box-Drive Spindle –Spindle Speed 8,000rpm(No.40)	○	○	○	○	N/A	○
19	Gear and Spindle-Drive –Spindle Speed 6,000rpm(No.40/50)	○	○	N/A	N/A	N/A	N/A
20	Gear and Spindle-Drive –Spindle Speed 6,000rpm(No.50)	N/A	N/A	○	○	○	○
21	C.T.S Interface	○	○	○	○	○	○
22	C.T.S with Filter System (Top Roof Must Included)	○	○	○	○	○	○
23	Top Roof	○	○	○	○	○	○
24	30T Nos. ATC/ 40T / 50T	○	○	○	○	○	○
25	CAT / DIN / HSK Tooling System	○	○	○	○	○	○
26	Oil-Water Separator	●	●	●	●	●	●
27	Oil Skimmer	○	○	○	○	○	○
28	Work Light	●	●	●	●	●	●
29	3-Color Signal Light	●	●	●	●	●	●
30	Rigid Tapping	●	●	●	●	●	●
31	Outside Air Blast	●	●	●	●	●	●
32	RS232 Interface	●	●	●	●	●	●
33	Ethernet Interface	●	●	●	●	●	●
34	Air gun / Coolant Gun Interface	●	●	●	●	●	●
35	Air Gun / Coolant Gun	○	○	○	○	○	○
36	Auto Power Off	●	●	●	●	●	●
37	Front Door Interlock	●	●	●	●	●	●
38	Y-Axis Rear Chip Flushing System	○	○	●	●	●	●
39	Chip Flushing System	○	○	○	○	○	○
40	Hight Pressure Coolant Pump	○	○	○	○	○	○
41	Chip Screws- Inside the Machine	○	○	●	●	●	●
42	Screw Type Chip Conveyor –Front, Left side / Right side Discharge & Chip bucket	○	○	○	○	○	○
43	Chip Conveyor - Front, Left Side /Right Side Discharge & Chip Bucket	○	○	○	○	○	○
44	Chip Conveyor - Folding Mechanism Design & Chip Bucket	N/A	N/A	N/A	N/A	○	○
45	3-Axes Linear Scale	○	○	○	○	○	○
46	4th or 5th Axis Preparation or Rotary Table Package	○	○	○	○	○	○
47	Auto Tool Length Measurement and Breakage Detection	○	○	○	○	○	○
48	Auto Workpiece Measurement	○	○	○	○	○	○
49	Transformer	○	○	○	○	○	○

● Standard ○ Optional N/A Not applicable

Machine Specifications

(*)Gear Sprcifications

MODEL	Unit	VBX-1100		VBX-1300		VBX-1400		VBX-1650		VBX-1900	VBX-2200	
		#40	#50	#40	#50	#40	#50	#40	#50	#50	#40	#50
TRAVEL												
X Axis Travel	mm	1100		1300		1400		1650		1900	2200	
Y Axis Travel	mm	610		610		800		800		860	960	
Z Axis Travel	mm	600		600		700		700		800	800	
Spindle Nose to Table Surface	mm	125-725		125-725		145-845		145-845		235-1035	235-1035	
Spindle Center to Column Surface	mm	660		660		850		850		950	1050	
Table Surface To Floor	mm	870		870		975		975		1025	1025	
Table Center To Column Surface	mm	355-965		355-965		450-1250		450-1250		520-1380	570-1530	
TABLE												
Table Dimension	mm	1300x600		1500x600		1650x800		1900x800		2100x860	2400x960	
Max.loading Weight	kg	1300		1300		1500		1800		2200	2700	
T-Slots (W×NO.×P)	mm	18x5x100		18x5x100		22x6x125		22x6x125		22x6x125	22x6x160	
SPINDLE												
Spindle Speed	rpm	10000(*8000)	4000(*8000)	10000(*8000)	4000(*8000)	10000	4000 (*6000)	10000	4000 (*6000)	4000 (*6000)	10000	4000 (*6000)
Spindle Taper		7/24 taper NO.40	7/24 taper NO.50	7/24 taper NO.40	7/24 taper NO.50	7/24 taper NO.40	7/24 taper NO.50	7/24 taper NO.40	7/24 taper NO.50	7/24 taper NO.50	7/24 taper NO.40	7/24 taper NO.50
Dia. of Spindle	mm	Ø70	Ø100 (*Ø85)	Ø70	Ø100 (*Ø85)	Ø70	Ø100 (*Ø100)	Ø70	Ø100 (*Ø100)	Ø100 (*Ø100)	Ø70	Ø100 (*Ø100)
Spindle Motor	kw	15/18.5/25 (*7.5/11)	15/18.5/25/30 (*15/18.5/25)	15/18.5/25 (*7.5/11)	15/18.5/25/30 (*15/18.5/25)	7.5/15	7.5/15 (*18.5/22/30)	7.5/15	7.5/15 (*18.5/22/30)	11/18.5 (*18.5/22/30)	11/18.5	11/18.5 (*18.5/22/30)
FEEDRATE												
Rapid Traverse X Axis	m/min	24		24		20		20		15	15	
Rapid Traverse Y Axis	m/min	24		24		20		20		15	15	
Rapid Traverse Z Axis	m/min	24		24		18		18		12	12	
AUTOMATIC TOOL CHANGER												
Tool Changer		ARM		ARM		ARM		ARM		ARM	ARM	
No. of Tools		24	24	24	24	24	24	24	24	32	32	32
Pull Stud		P-40T(45°)	P-50T(45°)	P-40T(45°)	P-50T(45°)	P-40T (45°)	P-50T (45°)	P-40T (45°)	P-50T (45°)	P-50T (45°)	P-40T (45°)	P-50T (45°)
Max. Tool Weight	kg	7	15	7	15	7	15	7	15	15	7	15
Max. Tool Length	mm	300	350	300	350	250	300	250	300	300	300	300
Max. Tool Diameter	mm	Ø80	Ø100	Ø80	Ø100	Ø80	Ø100	Ø80	Ø100	Ø100	Ø70	Ø100
Max. Tool Diameter (no Adjacent Tool)	mm	Ø150	Ø200	Ø150	Ø200	Ø150	Ø200	Ø150	Ø200	Ø200	Ø130	Ø200
Tool Changing Time (Tool to Tool)	sec/Hz	1.7/60 2.0/50	3.5/60 5.0/50	1.7/60 2.0/50	3.5/60 5.0/50	1.7/60 2.0/50	3.5/60 5.0/50	1.7/60 2.0/50	3.5/60 5.0/50	3.5/60 5.0/50	1.7/60 2.0/50	3.5/60 5.0/50
OTHER												
Floor Space	mm	3445x2775		3650x2760		4665x3185		4790x3185		5150x3770	5485x3770	
Machine Weight	kg	7500		8000		12000		13000		19000	22000	
Max. Machine Height	mm	2700(*2930)	3035(*2930)	2700(*2930)	3035(*2930)	3300		3300		3550 (*3530)	3530	3550 (*3530)
Power Capacity	KVA	35		35		35		35		35	35	
Air Source	bar	6-8		6-8		6-8		6-8		6-8	6-8	

* Specifications are subject to change without prior notice.