

MACHINE ACCESSORIES

Item	VMP-23(A)	VMP-23A-APC	VMP-30(A)	VMP-32(A)	VMP-32A-APC	VMP-40(A)	VMP-45(A)	VMP-50(A)	VMP-65(A)
3-Axis Pro-Tensioned Ball Screw	•	•	•	•	•	•	•	•	•
3-Color Signal Light	•	•	•	•	•	•	•	•	•
Automatic Lubrication System	•	•	•	•	•	•	•	•	•
Dust-Proof Electrical Cabinet	•	•	•	•	•	•	•	•	•
Ethernet Interface	•	•	•	•	•	•	•	•	•
Enclosed Splash Guard	•	•	•	•	•	•	•	•	•
Heat Exchanger	•	•	•	•	•	•	•	•	•
Outside Air Blast	•	•	•	•	•	•	•	•	•
Rigid Tapping	•	•	•	•	•	•	•	•	•
RS232	•	•	•	•	•	•	•	•	•
Spindle Air Blast	•	•	•	•	•	•	•	•	•
Spindle Air Sealing	•	•	•	•	•	•	•	•	•
Spindle Speed 10000 rpm(Belt-Steel Bearing)	•	•	•	•	•	•	•	•	•
Work Light*1	•	•	•	•	•	•	•	•	N/A
No Counter Weight (Z axis servo motor with brake)	•	•	•	•	•	•	•	•	N/A
Rear Exit Chip Flushing System	•	•	•	○	•	○	•	•	•
24T Nos. ATC	○	○	○	•	•	•	•	•	•
Spindle Coolant Nozzle	○	○	○	•	•	•	•	•	•
Air Gun Interface	○	○	○	•	•	•	•	•	•
Oil-Water Separator	N/A	N/A	N/A	•	•	•	•	•	•
X/Y/Z Axes with Linear Guide	•	•	•	○	○	○	○	○	○
X/Y Axes with Linear Guide, Z axis with box way	N/A	N/A	N/A	•	•	•	•	•	•
Front Side Chip Flushing System	N/A	N/A	N/A	•	N/A	•	○	○	N/A
Work Light*2	○	○	○	○	○	○	○	○	•
30T Nos. ATC	N/A	N/A	N/A	○	○	○	○	○	○
4/5 Axes Interface	○	○	○	○	○	○	○	○	○
40T Nos. ATC	N/A	N/A	N/A	N/A	N/A	N/A	N/A	N/A	○
4th Axis Interface	○	○	○	○	○	○	○	○	○
Air Condition	○	○	○	○	○	○	○	○	○
Auto Tool Length Measurement	○	○	○	○	○	○	○	○	○
Auto Workpiece Measurement	○	○	○	○	○	○	○	○	○
Automatic Door	○	○	○	○	○	○	○	○	○
Automatic Power Off	○	○	○	○	○	○	○	○	○
C.T.S with Filter System(top roof must included)	○	○	○	○	○	○	○	○	○
Chip Conveyor-Left/Right Side Discharge & Chip Bucket	N/A	N/A	N/A	○	N/A	○	○	○	N/A
Chip Flushing System	○	○	○	○	○	○	○	○	○
Column Raiser	○	○	○	○	○	○	○	○	○
Coolant Gun	○	○	○	○	○	○	○	○	○
CTS Interface	○	○	○	○	○	○	○	○	○
Dual-Chip Augers (With Chip Conveyor)	N/A	N/A	N/A	○	○	○	○	○	○
GTP Two-Stage Gearbox	N/A	N/A	N/A	○	○	○	○	○	N/A
High Pressure Pump	○	○	○	○	○	○	○	○	○
Linear Scale	○	○	○	○	○	○	○	○	○
Oil Skimmer	○	○	○	○	○	○	○	○	○
Screw type Chip Conveyor-Left/Right Side Discharge & Chip Bucket	N/A	N/A	N/A	○	N/A	○	○	○	N/A
Spindle Oil cooler	○	○	○	○	○	○	○	○	○
Spindle Speed 10000/12000 rpm(DDS)	○	○	○	○	○	○	○	○	○
DDS 15000 rpm(include temperature compensation)	○	○	○	○	○	○	○	○	○
Temperature Compensation	○	○	○	○	○	○	○	○	○
Spindle Speed 12000 rpm(Belt-Ceramic Baring)	○	○	○	○	○	○	○	○	○
Top Roof	○	○	○	○	○	○	○	○	○
Z axis with Roller Type Linear Guide	○	○	○	○	○	○	○	○	N/A

• :Standard ○ : Optional N/A : Not available



HEADQUARTERS
 No. 186, Yong Chi Road, Taipei, Taiwan.
 Tel: +886-2-2763-9696
 Fax: +886-2-2768-0636/37/39
 www.fg-tw.com
 E-mail: chairom@fairfriend.com.tw



FEELER MACHINE TOOLS DIVISION
 No. 12, Jingke Rd., Nantun Dist., Taichung City, Taiwan
 Tel: +886-4-2359-4075
 Fax: +886-4-2359-4873
 www.feeler.com
 E-mail: sales@feeler.com



18.05.1000-S601000001



VMP SERIES

Vertical Machining Center

FEELER VMP SERIES

Vertical Machining Center Provides State-of-the-art Efficiency For Increased Profitability

Whether you require in high precision parts machining or general mold making, Fair Friend's new VMP-Series Vertical Machining Centers offers unbeatable dependability.

The VMP-Series is a well-engineered high precision unit, ideal for various precision industrial requirements. It promises dramatic productivity gains with many integrated features. Its rugged structure, manufactured from high quality cast iron, assures optimum rigidity and stability for years of dependable operation. The Machine structure design is subject to ANSYS and NASTRAN Finite Element Analysis to achieve the highest standards of machine accuracy and reliability.

Reinforced A-shape column bottom is combined with a massive base for extra rigid support. The 10,000 rpm spindle speed produces the fine surface effect required by precision mold. With the points above and more excellent features combination, you get the most Competitive edge for your precision jobs.



■ VMP-23A/30A



■ VMP-32A/40A



■ VMP-45A



■ VMP-23Aapc



■ VMP-32Aapc



■ VMP-50A



■ VMP-65A



Perfected structure design brings you lifetime accuracy, rigidity and stability !

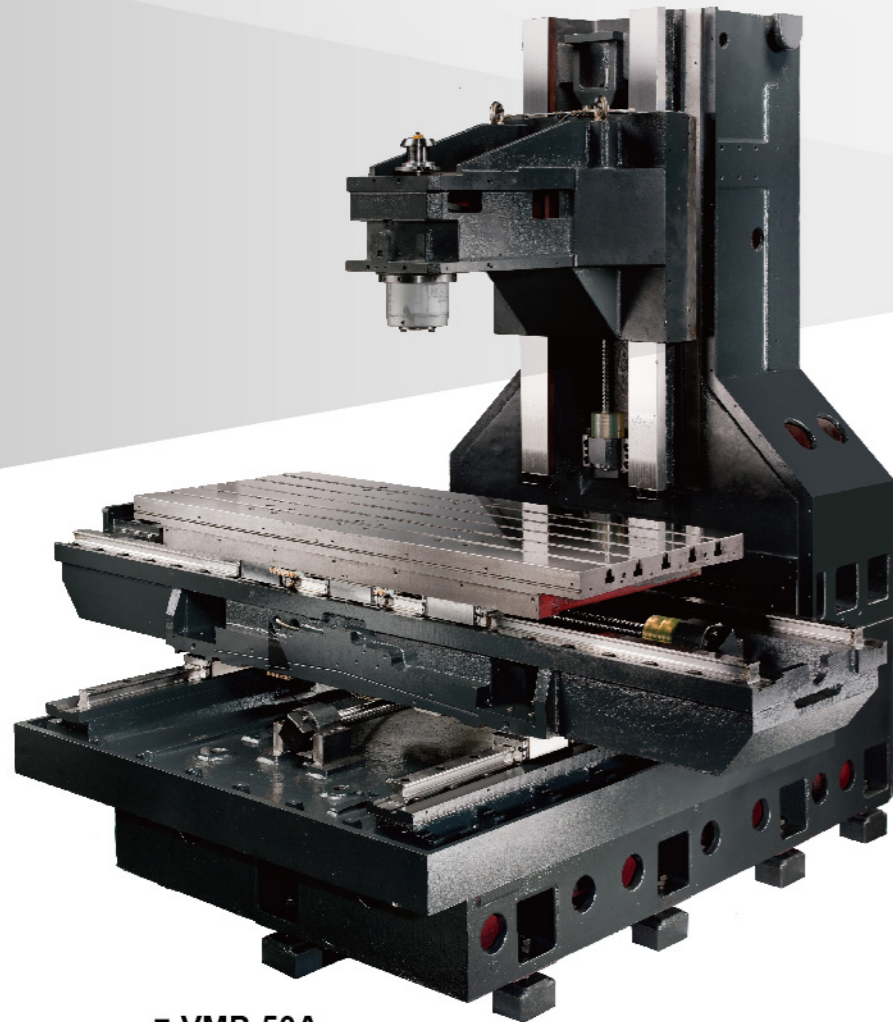

■ VMP-50A

Rear mounted Y-axis servo motor for increased maintenance space.

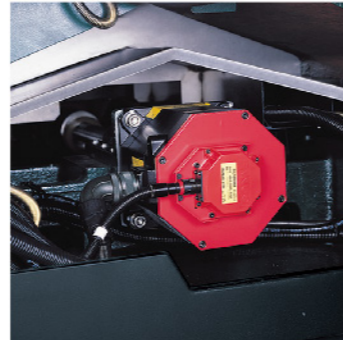

RUGGED CONSTRUCTION ASSURES OPTIMUM RIGIDITY AND STABILITY

- The machine structure and major parts are manufactured from Meehanite cast iron for outstanding material stability and guaranteed long-term deformation-free performance.
- The entire machine construction is subjected to ANSYS and NASTRAN Finite Element Analysis to achieve optimum rigidity and stability.
- The column bottom is specially designed with A-shaped structure. (Except VMP23.30)
- Outstanding machine structure, combined with high speed servo system, allows rapid traverse up to 40 m/min.
- Servomotor directly drives ballscrew. Ballscrews are pretensioned, ensuring rigidity and accuracy required for the feed transmission system.
- Boxways for Z axis are coated with low friction Turcite B, providing increased cutting rigidity. (Except VMP23.30)
- 634mm span of guideways on Y-axis and 370mm span on Z-axis guarantee superior stability for saddle and spindle head travel.

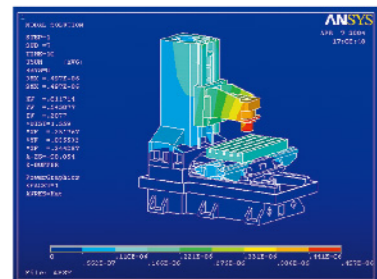

FEM ANALYSIS

FEELER'S machine structure is designed and analyzed using advanced Finite Element Analysis software for dynamic simulation and structural analysis. This design method assures optimum structural rigidity, machine accuracy and reliability.

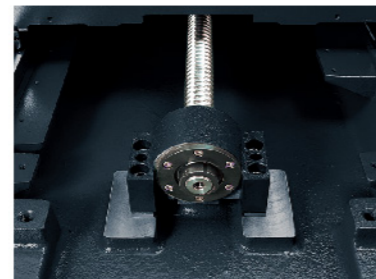

PRECISION BALLSCREWS

Pretensioned ballscrews on X, Y, Z axes ensure accuracy and eliminate positioning errors.

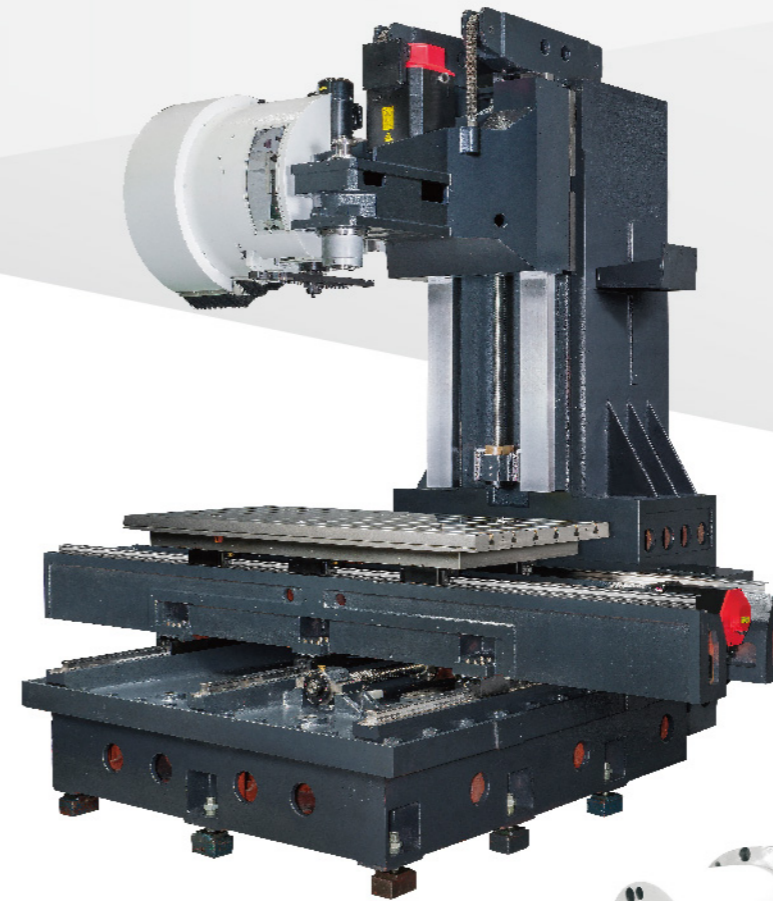
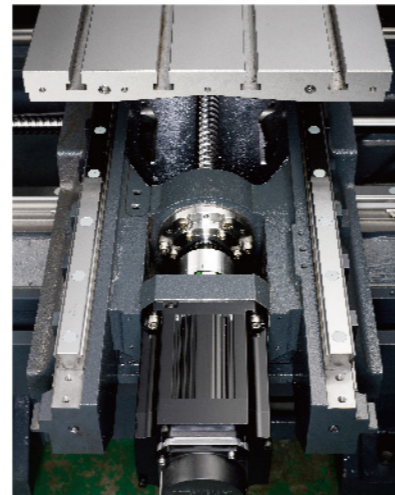

■ VMP-65A
(3 linear guide ways)



Dependable, Efficient ATC

FEELER'S ATC designs are all subjected to 1 million cycles of continuous tests for durability and stability to assure maximum dependability of operational performance.

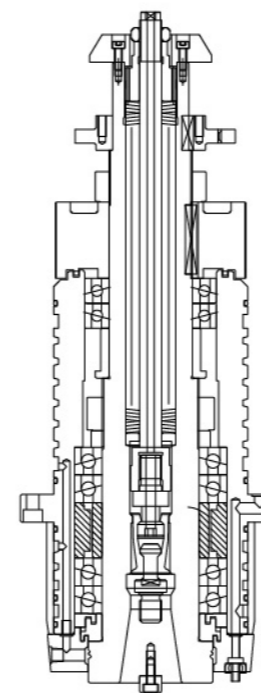

10,000 RPM SPINDLE

The belt-drive spindle specially-designed bearing layout ensures maximum spindle rigidity. (Spindles at 10,000rpm and 12,000rpm are available as optional.)

Cutting Capacity Example

Workpiece Material: Medium Carbon Steel (S45C)

Machining Types		
Drilling	Tapping	Face Milling
Tool Diam. (mm) x Feed (mm/rev)	Tool Diam. (mm) x Pitch (mm/rev)	Width (mm) x Depth (mm) x Feed (mm/min)
Ø40 x 0.1	M24 x 3.0	308 c.c. 80 x 3.5 x 1100

Pragmatic Operational Features



SEE-THROUGH WINDOW

The additional see-through window on the spindle head cover provides convenient checking.

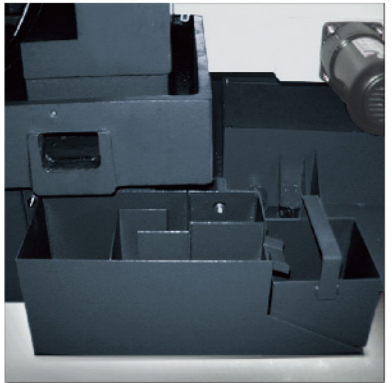

OIL / COOLANT SEPARATION DEVICE

Mounted at the side of the base, the oil/coolant separation device does not require additional leveling adjustment.

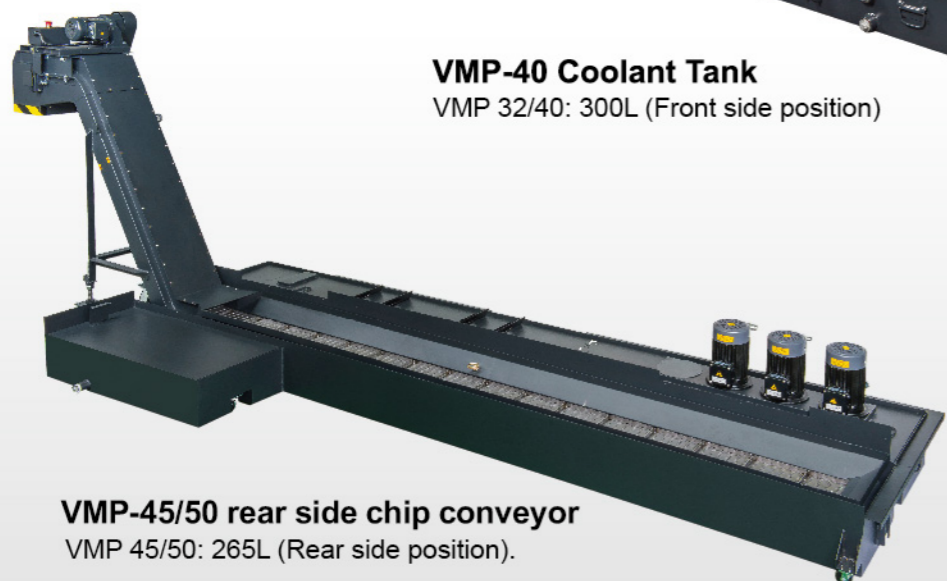

VMP-45/50 rear side chip conveyor
VMP 45/50: 265L (Rear side position).

CHIP CONVEYOR (opt.)

- * Chip conveyor of VMP series is with left side discharge (right side discharge is available upon request).
- * VMP32A/40A's chip conveyor is placed in front side with left side discharge, please refer to above drawing.
- * VMP23A/30A/45A/50A's chip conveyor is placed in the rear side of machine with left side discharge.

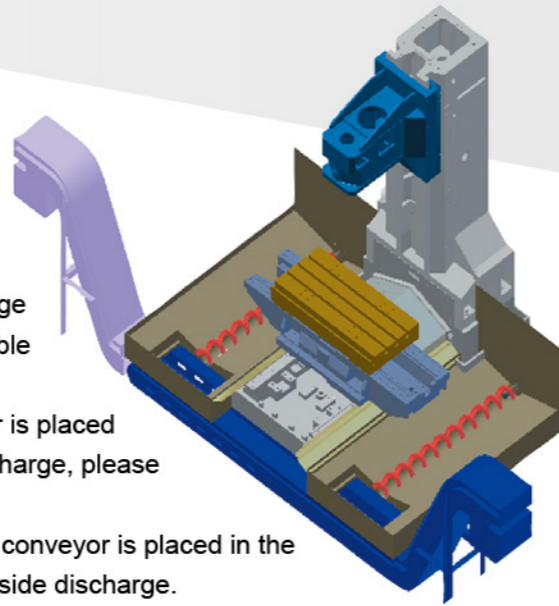

VMP-30 Rear Side Coolant Tank



VMP-40 Coolant Tank

VMP 32/40: 300L (Front side position)

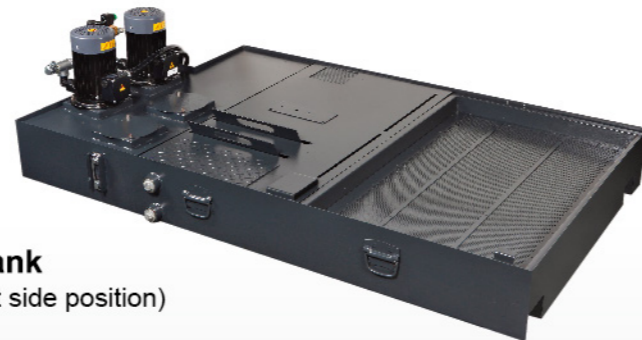

VARIOUS ADVANCED CNC CONTROLLERS TO CHOOSE FROM

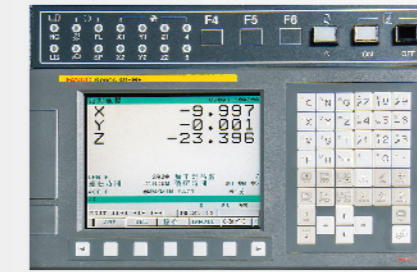

FANUC Oi MF



MITSUBISHI M80



HEIDENHAIN TNC 640



SIEMENS 828D

An Innovative Structural Design that Allows for Many Options

Mold Machining Package (OPT)

- 10,000 rpm spindle speed (Ceramic Bearing)
- 15/18.5 kW spindle power (Except VMP-23A/30A)
- 12 (24) m/min. rapid traverse on X / Y / Z-axis
- AICCI+ Data Server + Ethernet

Precision Mold Machining Package (OPT)

- 10,000 rpm spindle speed (Ceramic Bearing)
- 15/18.5 kW spindle power (Except VMP-23A/30A)
- 12 (24) m/min. rapid traverse on X / Y / Z-axis
- 12,000 / 15,000 rpm DDS. spindle (Except VMP-23A/30A)
- Z-axis roller type linear guide
- AICC II+ Data Servo + Ethernet + Manual guide i
- Jerk Control + Machining Conditions selection: 10-step speed change + NaNo smoothing
- Rear cover

INTELLIGENT PARAMETER ADJUSTMENT FUNCTION

The NC automatically evaluates and executes parameter compensation according to the machining condition.

1. BEFORE COMPENSATION

Sharp point occurs during quadrant change.

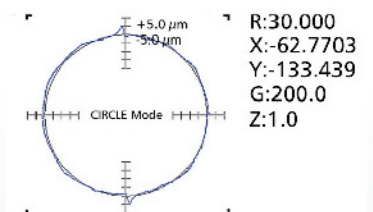

2. DURING COMPENSATION

The intelligent parameter adjustment function eliminates the sharp points on quadrants.

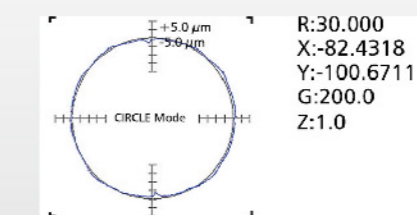

3. AFTER COMPENSATION

Circularity accuracy is greatly elevated.

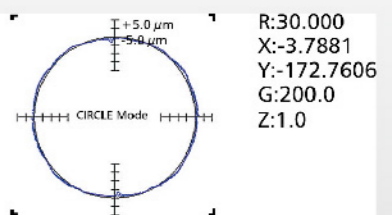

SERVO SYSTEM ADJUSTMENT AND OPTIMIZATION

The servo system can be adjusted to an optimum condition according to the signals from each axis movement. This provides:

- Increased servo system rigidity.
- Reduced machine vibration.
- Reduced machining time.
- Optimization for acceleration/deceleration time before and after interpolation.

This function meets the rigorous requirements of surface roughness and smoothness for the mold-making industry. Also, it greatly reduces machining time for maximum efficiency.

- BLUE CURVE: Torque command
- RED CURVE: Position
- GREEN CURVE: Speed
- PURPLE CURVE: Acceleration

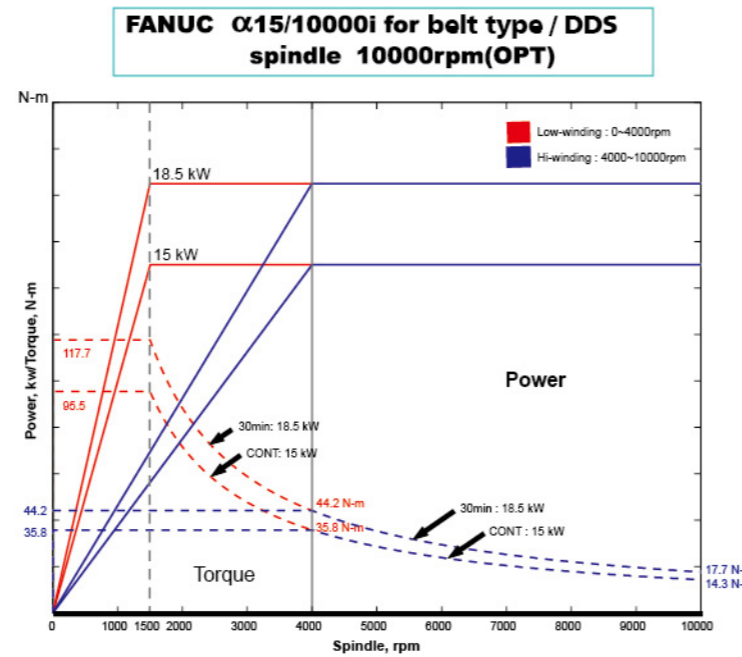
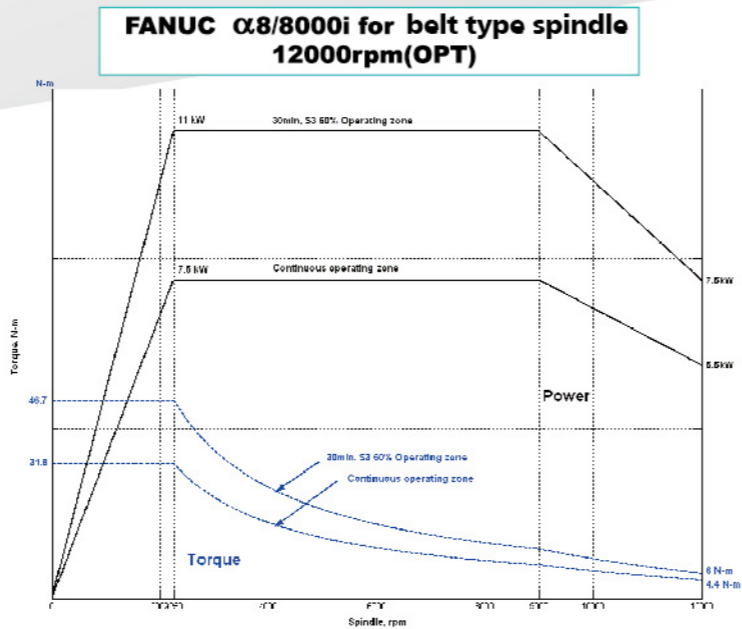
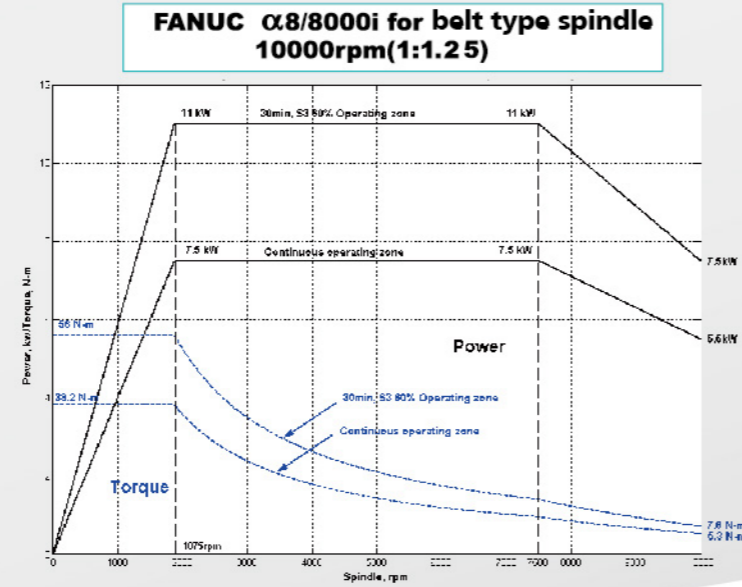
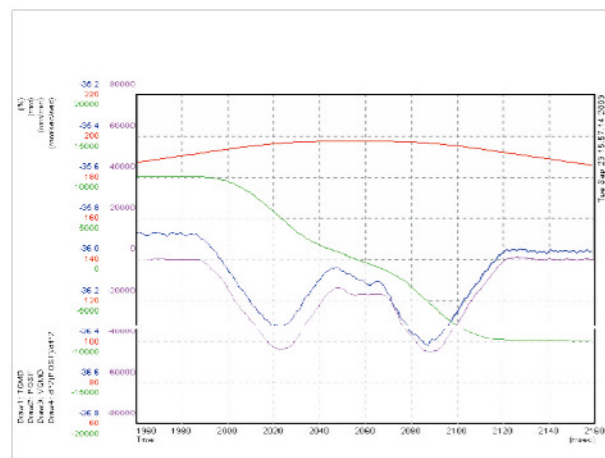
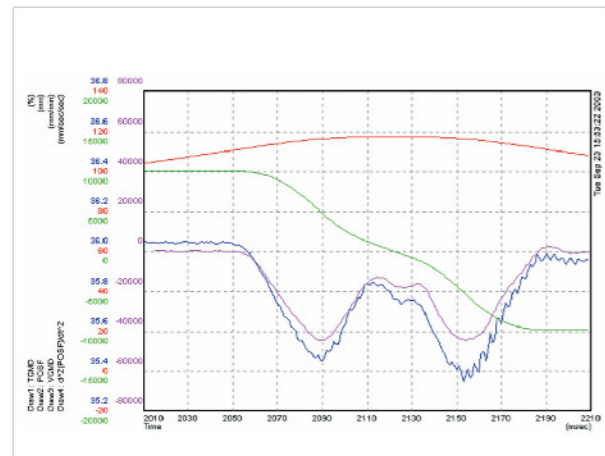

Machine Dimensions, Table Dimensions and Working Capacity

VMP-23 VMP-30

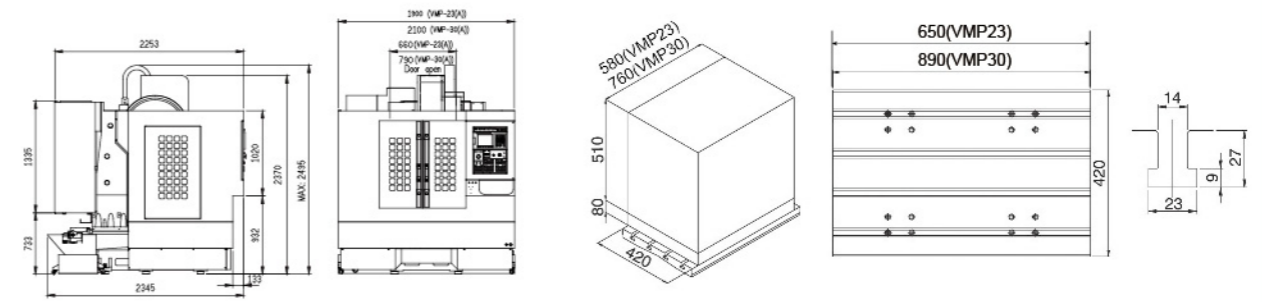

VMP-32 VMP-40

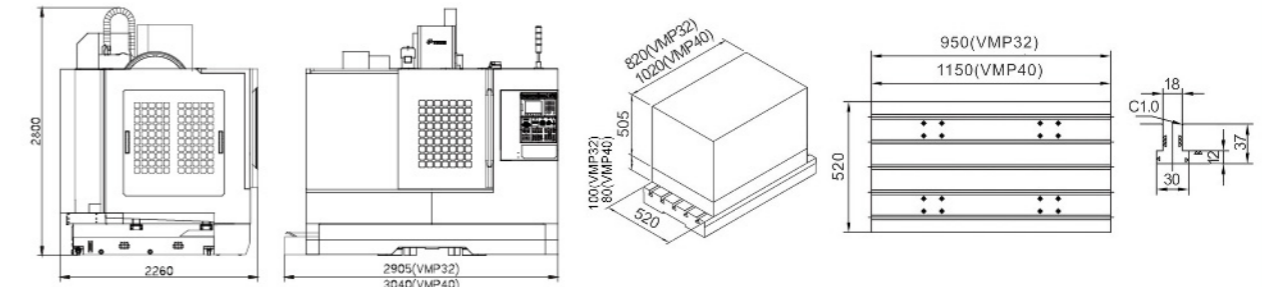

VMP-45

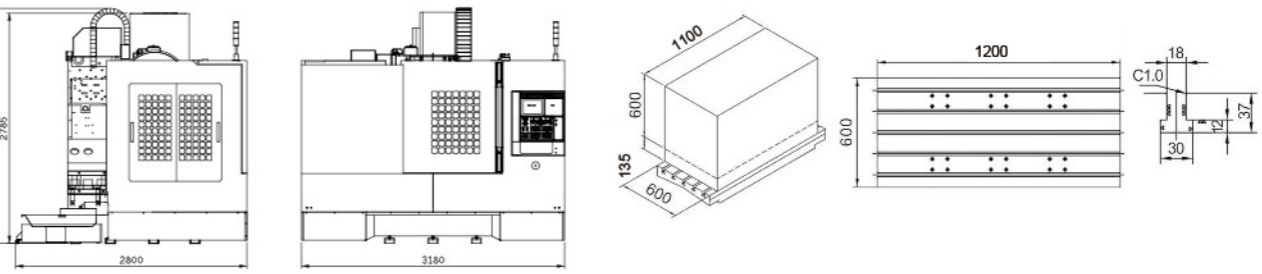

VMP-50

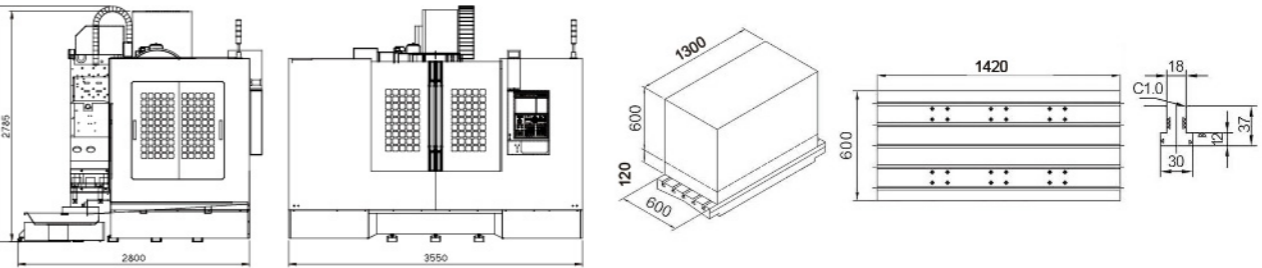

VMP-65

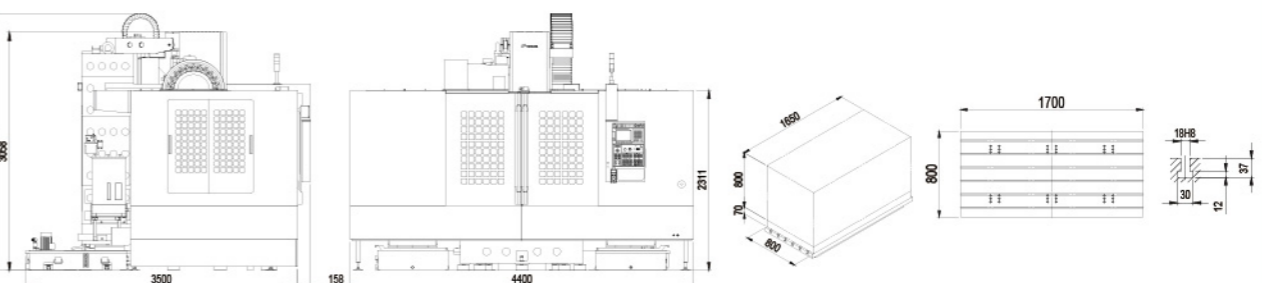

VMP MACHINE SPECIFICATIONS

MODEL	Unit	VMP-23(A)	VMP-23A-APC	VMP-30(A)	VMP-32(A)	VMP-32A-APC	VMP-40(A)	VMP-45(A)		VMP-50(A)		VMP-65(A)
TRAVEL								BT40	BT50	BT40	BT50	BT-40
X - axis travel	mm	580	580	760	820	800	1,020	1,100		1,300		1,650
Y - axis travel	mm	420	420	420	520	520	520	610		610		800
Z - axis travel	mm	510	510	510	505 (OPT:635)	505	505 (OPT:635)	600		600		800
Spindle nose to table surface	mm	80 ~ 590	135 ~ 645	80-590	100 ~ 605 (OPT:80~715)	148 ~ 653	80 ~ 585 (OPT:80~715)	135 ~ 735		120 ~ 720		70~870
Spindle center to column surface	mm	455	455	455	560	560	560	660		660		850
Table surface to floor	mm	820	915	820	920	1025	940	960		975		1,080
Table center to column surface	mm	245 ~ 665	245 ~ 665	245 ~ 665	300 ~ 820	300 ~ 820	300 ~ 820	355~965		355~965		450~1,250
TABLE												
Table dimensions	mm	650 x 420	580 x 410	890 x 420	950 x 520	700 x 500	1,150 x 520	1,200 x 600		1,420 x 600		1,700 x 800
Maximum load	kg	300	120	300	800	200	800	1,500		1,500		1,500
T - slot	mm	14 x 4 x 100	35-M12 x P1.75	14mm x 4 x 100	18 x 5 x 100	35-M16 x P2.0	18 x 5 x 100	18 x 5 x 100		18 x 5 x 100		18 x 6 x 125
SPINDLE												
Spindle speed	rpm	10,000	10,000	10,000	10,000	10,000	10,000	10,000	4,000	10,000	4,000	10,000
Spindle taper	type	7/24 taper No.40	7/24 taper No.40	7 / 24 taper No.40	7/24 taper No.40	7/24 taper No.40	7/24 taper No.40	7/24 taper No.40	7/24 taper No.50	7/24 taper No.40	7/24 taper No. 50	7/24 taper No.40
Spindle power	kW	7.5 / 11	7.5 / 11	7.5 / 11	7.5 / 11	7.5 / 11	7.5 / 11	15 / 18.5		15 / 18.5		15/18.5
FEEDRATE												
X - axis rapid traverse	m / min	36	36	36	40	40	40	36		36		36
Y - axis rapid traverse	m / min	36	36	36	40	40	40	36		36		36
Z - axis rapid traverse	m / min	36	36	36	30	30	30	24		24		24
ATC												
Tool changing time (tool-to-tool)	Carousel type	7 sec / 60 Hz, 7.1 sec / 50 Hz	No	7sec / 60Hz, 7.1sec / 50Hz	7 sec / 60 Hz, 7.1 sec / 50 Hz	7 sec / 60 Hz, 7.1 sec / 50 Hz	7 sec / 60 Hz, 7.1 sec / 50 Hz	7 sec / 60 Hz, 7.1 sec / 50 Hz	7 sec / 60 Hz, 7.1 sec / 50 Hz	7 sec / 60 Hz, 7.1 sec / 50 Hz	7 sec / 60 Hz, 7.1 sec / 50 Hz	7sec / 60 Hz, 7.1 sec / 50Hz
	Arm type	1.7 sec / 60 Hz, 2.0 sec / 50 Hz	1.7 sec / 60 Hz, 2.0 sec / 50 Hz	1.7 sec / 60 Hz, 2.0 sec / 50 Hz	1.7 sec / 60 Hz, 2.0 sec / 50 Hz	1.7 sec / 60 Hz, 2.0 sec / 50 Hz	1.7 sec / 60 Hz, 2.0 sec / 50 Hz	1.7 sec / 60 Hz, 2.0 sec / 50 Hz	1.7 sec / 60 Hz, 2.0 sec / 50 Hz	1.7 sec / 60 Hz, 2.0 sec / 50 Hz	1.7 sec / 60 Hz, 2.0 sec / 50 Hz	1.7sec / 60 Hz, 2.0 sec / 50Hz
Tool changer		Carousel (Arm)	Arm	Carousel (Arm Type)	Carousel (Arm)	Carousel (Arm)	Carousel (Arm)	Carousel (Arm)		Carousel (Arm)		Carousel(Arm)
No. of tools	type	18 (20)	20	18 (20)	22 (24)	22 (24)	22 (24)	22(24)		22(24)		22(24)
Pull stud		P-40T (45°)	P-40T (45°)	P - 40T (45°)	P-40T (45°)	P-40T (45°)	P-40T (45°)	P-40T (45°)	P-50T (45°)	P-40T (45°)	P-50T (45°)	P-40T(45°)
Max. tool weight	kg	7	7	7	8	8	8	8	15	8	15	8
Max. tool length	mm	250	250	250	300	300	300	300	350	300	350	300
Max. tool diameter	mm	Ø80	Ø80	Ø80	Ø80	Ø80	Ø80	Ø80	Ø100	Ø80	Ø100	Ø80
Max. Tool diameter (no adjacent tool)	mm	Ø130	Ø130	Ø130	Ø150	Ø150	Ø150	Ø150	Ø200	Ø150	Ø200	Ø150
OTHERS												
Floor space	mm	1,900 x 2,255	1,900 x 2,630	2,100 x 2,255	2,905 x 2,260	3,300 x 3,175	3,040 x 2,260	3,180 x 2,800		3,550 x 2,800		4,400 x 3,500
Machine weight	kg	3,000	3,900	3,300	5,800	7,500	6,300	6,800		7,300		12,300
Max. machine height	mm	2,495	2,520	2,495	2,800	2,950	2,800	2,900		2,900		3,300
Power capacity	KVA	30	30	30	35	35	35	30(35)		30(35)		30(35)
Air source	kg/cm ²	6-8	6-8	6-8	6-8	6-8	6-8	6-8		6-8		6-8

* APC changing time: 6 seconds/ VMP-23A-APC, 10 Seconds/ VMP32A-APC.
 * Specifications and design characteristics are subject to change without prior notice.

(Controller : Fanuc / Mitsubishi) (Controller : Fanuc / Mitsubishi)

