

型號	MODEL	VITO-12	VITO-16	VITO-20	VITO-26	VITO-32	VITO-34	VITO-36	VITO-38	VITO-42	VITO-45	VITO-51	VITO-56
規格	SPECIFICATIONS	2.0M / 2.5M / 3.0M / 3.6M / 4.2M											
料管尺寸	GUIDE CHANNEL	13 mm	17 mm	21 mm	27 mm	33 mm	35 mm	37 mm	39 mm	43 mm	46 mm	52 mm	57 mm
棒材直徑	BAR DIAMETER	5-12 mm	5-16 mm	5-20 mm	5-26 mm	5-32 mm	5-34 mm	5-36 mm	5-38 mm	5-42 mm	5-45 mm	8-51 mm	8-56 mm
棒材容量	BAR CAPACITY	10 mm / 26 pcs											
棒材長度	BAR LENGTH	2200 / 2700 / 3200 / 3800 / 4400 mm											
機械總重	MACHINE WEIGHT	2.0M - 800kg / 2.5M - 900kg / 3.0M - 980kg / 3.6M - 1060kg / 4.2M - 1200kg											
空壓系統	AIR PRESSURE	6 kgf / cm <sup>2</sup> 70psi											
傳動系統	TRANSMISSION	SERVO MOTOR											
油口	LUBRICANT	FK ISO VG68/ FK HYDRAULIC OIL 68											
油箱容量	CAPACITY	38L (10 GALLON)											
消耗功率	POWER CONSUMPTION	795W											
電源供應	POWER SUPPLY	3ø x 220V 50/60Hz											

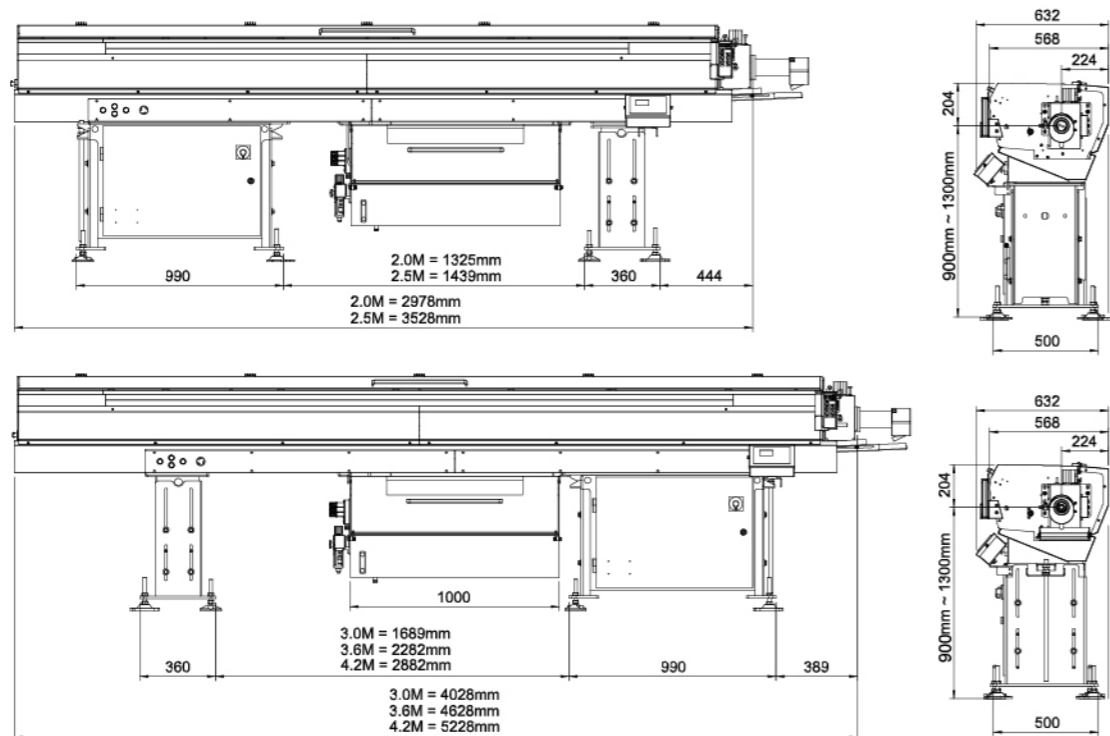

規格如有更改，恕不另行通知。 The spec is subject to change without prior notice.



**富豪機電股份有限公司**  
**BARLOAD MACHINE CO., LTD.**

No. 138, Wei-Hsin Road, Shi-Pai Li, Chang-Hua City, Taiwan 50080  
 50080彰化市石牌里維新路138號  
 TEL: +886-4-7384895 FAX: +886-4-7320282  
 E-mail: info@barload.com.tw

www.barload.com.tw

經銷商 Agent

本公司保留設計變更的權利 All Rights Reserved.

ACW 2017.09.1000CE



www.barload.com.tw



創新研發 · 台灣領航  
 品質追求 · 世界第一

Quality Innovation  
 Reliability Experience

**VITO 542**  
 系列 Series  
 5 - 56 mm

**HYDRODYNAMIC BAR FEEDER**

長 棒 材 送 料 機

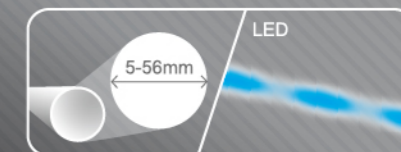



**LED遠端監控**  
LED-stripe Display Features Operative Status

- » LED燈光外部顯示器，送料加工中棒材長度、換料、送料機異常、車床異常等訊息經LED燈光顯示以視覺表現，方便工作人員遠距離監控。(專利)
- » Equipped with LED external display, message shown on the HMI display like bar length, bar position while fed. (patented)



**智慧型人機介面**  
Fuzzy Human Machine Interface

- » 專用式人機面板，設定操作簡單，並內建多功能模式選擇，以因應不同使用需求。
- » Multi-function features with Human-machine-interface display. Friendly user.

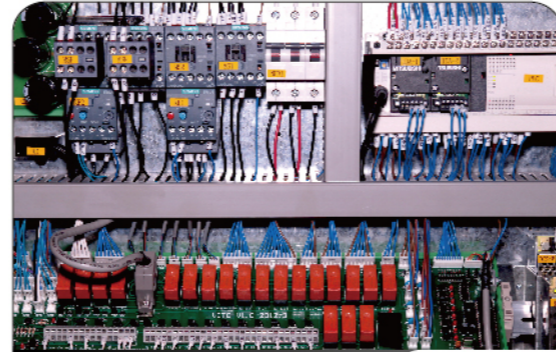

**電控系統**  
Electrical System

- » 口功能三菱PLC控制器與口方位資料庫軟體概念，送料工作中位置、扭力、速度，搭配車床控制精準。
- » All new functions : Mitsubishi PLC data bank. Feeding position, torque and speed are accurately and perfectly interfaced with lathes.



**防震系統**  
Anti-vibration System

- » V型防震塊組，依棒材大小調整防震，節省更換時間及防震塊費用，並可使用圓形防震塊組。
- » Easy adjusting anti-vibration device, without change-over.



**手控器**  
Movable Remote Controller

- » 移動式手控盒，操作容易簡便，符合人體工學。固定座設計，不易脫落。
- » Remote control box greatly increases operational convenience and meets ergonomics plus a durable holder.

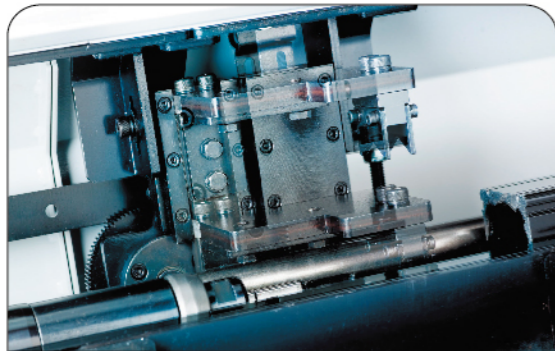

**免調整夾料系統**  
Clamping-device Requires No Adjustment

- » 材料尺寸大小無需調整，挾持力量增強，挾持不鬆脫省時方便。
- » A beefed-up clamping structure.



- 夾料免調整。(專利)
- 隱藏式高安口性配線。
- 換料時間快速。
- 可依實際需求，調整扭力及速度。
- 油與殘料分離收集設計。
- 已通過CE認證。

- Adjustment-free for sizing bar materials. (patented)
- Hidden-and-secured wirings.
- Speedy bar-change.
- Adjustable torque force and speed.
- Well-designed for separating lubricant drain and remnant collection.
- CE certificated.

**VITO 542**  
系列 Series

**HYDRODYNAMIC BAR FEEDER**

長 棒 材 送 料 機