

型號	MODEL	BA-65	BA-65L
棒材長度	BAR LENGTH	1.2M	1.5M
機械總重	MACHINE WEIGHT	320 KGS	360 KGS
棒材直徑	BAR DIAMETER	5-65mm	
棒材容量	BAR CAPACITY	65mm/10pcs	
空壓供應	AIR PRESSURE	6 kgf / cm <sup>2</sup> 70psi	
電源供應	POWER SUPPLY	220V	
消耗功率	POWER CONSUMPTION	200W	

若需要其他資料請上網查詢 Check our website for more details at [www.barload.com.tw](http://www.barload.com.tw)  
 本公司保留設計變更的權利 Modifications are subject to change without prior notice.

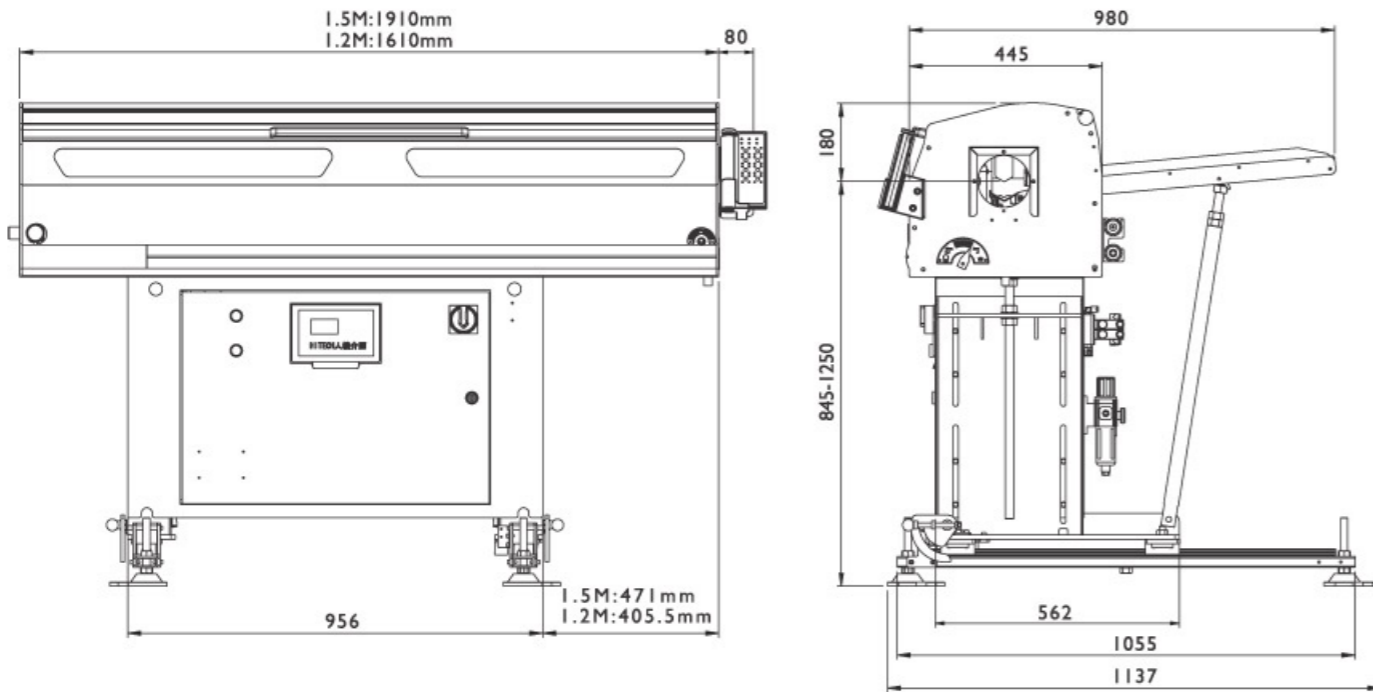

**富豪機電股份有限公司**  
**BARLOAD MACHINE CO., LTD.**

No. 138, Wei-Hsin Road, Shi-Pai Li, Chang-Hua City, Taiwan 50080  
 50080彰化市石牌里維新路138號  
 TEL: +886-4-7384895 FAX: +886-4-7320282  
 E-mail: info@barload.com.tw

[www.barload.com.tw](http://www.barload.com.tw)

經銷商 Agent

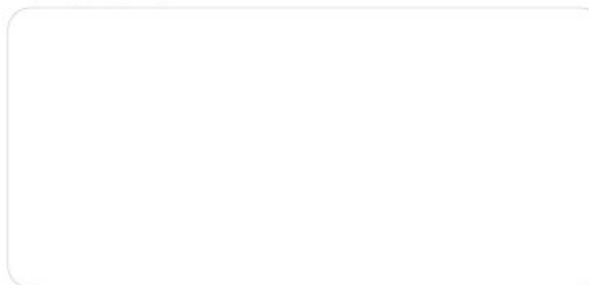

本公司保留設計變更的權利 All Rights Reserved.

1493210000213CE-1



[www.barload.com.tw](http://www.barload.com.tw)



創新研發 · 台灣領航  
 品質追求 · 世界第一

Quality Innovation  
 Reliability Experience

**BA 65**  
 系列 Series  
 5 - 65 mm

**SHORT BAR FEEDER**

短棒材送料機



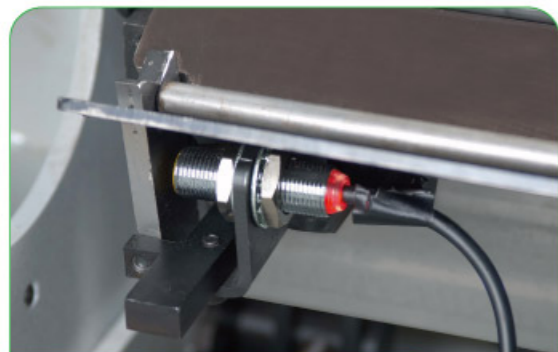

**切端結構**  
Top-cut Configuration

- » 切端機構穩定，小棒材亦可精密偵測。
- » A top-cut device senses bar sizes accurately.

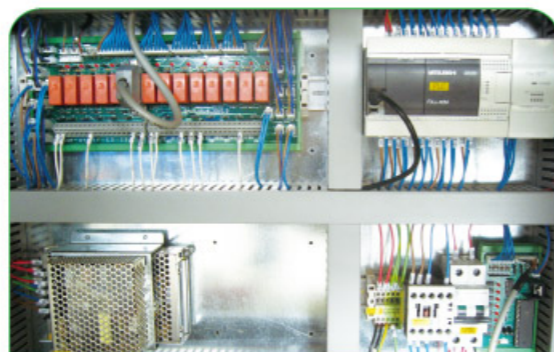

**電控系統**  
Electrical System

- » 內部PLC控制，易與任何CNC車床搭配。
- » A PLC controller smartly interfaces with various fixed-type lathe source.

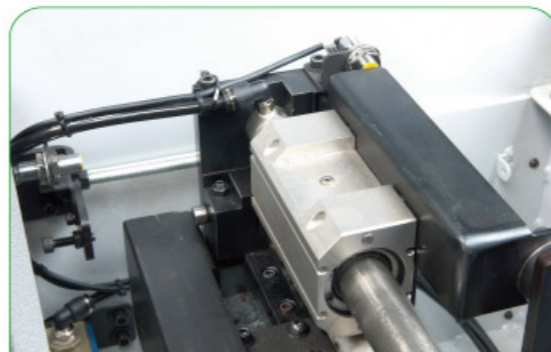

**平移定位**  
Parallel Positioning

- » 定位機構，精準順暢。
- » A prompt shaft feeding.



**送料—線性滑軌**  
Feeding-Linear-guide-way Device

- » 氣壓無桿缸與線性滑軌結合，動力輕盈順暢，不易脫磁。
- » A rodless-cylinder-and-linear-guide system functions efficiently.



**中心調整**  
Adjustable Loading Center

- » 材料尺寸機構易於調整，簡單快速。
- » A quick changeover runs smoothly for bar sizes in diameters.



**手控器**  
Movable Remote Controller

- » 手控盒，易於操作，符合人體工學。
- » A remote controller is as friendly-user.



**移動式腳架**  
Retraction Device (Movable Rall)

- » 移動式腳盤，方便主軸維修，更換皮帶，主軸襯套。  
(選購 X 向 及 Z 向 兩種規格)
- » Optional X or Z-axis device allows an easy change of lathe spindle liners.

- 可提昇CNC車床加工中，工件速度與精密度，無震動問題。
- 黑皮材料，可適用。
- BA-65送料機佔地空間小。
- 人機界面控制，操作與設定異常故障排除容易。
- 移動式手控盒，方便操作，符合人體工學。

- 線性滑軌推料，車床夾頭開時，使材料送達機料塊時，輕而順暢。
- 下料、調整機構，簡易方便。
- 移動式腳盤，方便主軸維修、更換皮帶、主軸襯套。(選購)
- 外部LED顯示位置棒材長度及異常訊息明顯易見。
- 新下料方式，減少噪音，調整方便。

- Increases productivity and cuts making cost hugely.
- Suits bar materials such as shapes & profiles.
- Requires no roomy space to accommodate it with.
- Friendly user with a human-machine-interface application.
- Feed materials accurately with a linear-guide system.
- An easy changeover with a V-channel-loading system.
- An external LED-stripe display features bar position & length while fed.
- Offers a free vibration condition with unlimited RPM.

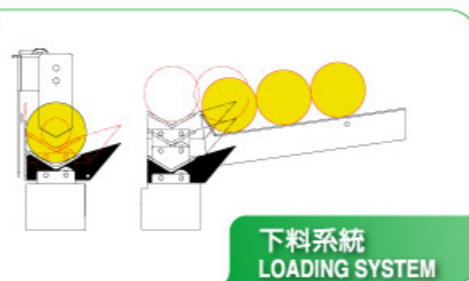

**下料系統**  
LOADING SYSTEM

**BA 65**  
系列 Series

**SHORT BAR FEEDER**

短棒材送料機