

▲面銑刀柄端面經特殊研磨，刀盤裝上後能與刀柄緊密貼合，使刀盤能穩固地進行切削，達到最佳的銑削效果。  
The face mill holder end face is precisely ground, so that the connection of the tool disk and holder is perfect, it is suitable for rough processing and can achieve optimal cutting performance.

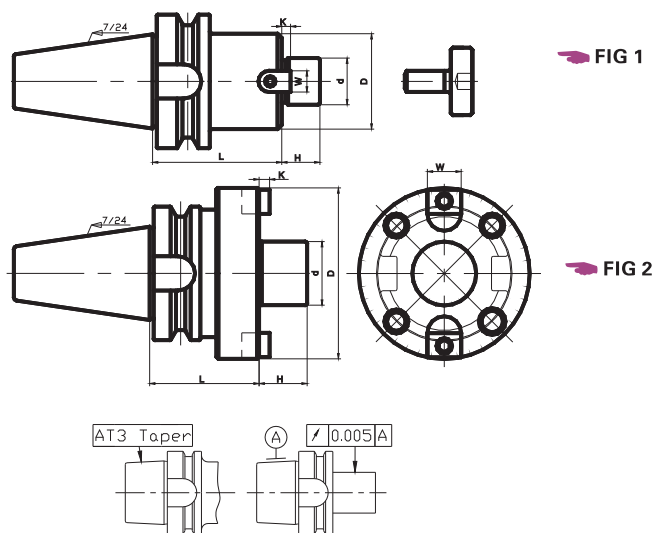

注：帶“\*”規格為加長型非標產品，如有需要請致電本司諮詢。  
The "\*" model is for extension types, it is not a standard product, please order them additionally if necessary.

訂貨型號 Order Code	圖號 FIG	L	ød(h6)	øD	H	K	W	重量(Kg) Weight
BT30-FMA25.4-45	1	45	25.4	50	20	5	9.5	0.9
-FMA38.1-60		60	38.1	80	25	9	15.9	2.1
BT40-FMA25.4-45	1	45	25.4	50	20	5	9.5	1.4
-60		60						1.7
-105		105						2.4
-150		150						3.1
-200		200						3.8
-250*		250	4.6					
-FMA31.75-45		45	31.75	60	22	7	12.7	1.6
-60		60						2.0
-90		90						2.7
-FMA38.1-60		60	38.1	80	25	9	15.9	2.5
BT50-FMA25.4-45	1	45	25.4	50	20	5	9.5	4.0
-90		90						4.6
-105		105						4.9
-150		150						5.6
-200		200						6.4
-250*		250	7.2					
-FMA31.75-45		45	31.75	60	22	7	12.7	4.1
-75		75						4.8
-105		105						5.5
-150		150						6.4
-200	200	7.6						
-FMA38.1-45	1	45	38.1	80	25	9	15.9	4.5
-75		75						5.6
-FMA50.8-45	1	45	50.8	100	28	12	5.4	
-FMA47.625-75	2	75	47.625	128	32	12.5	25.4	8.2

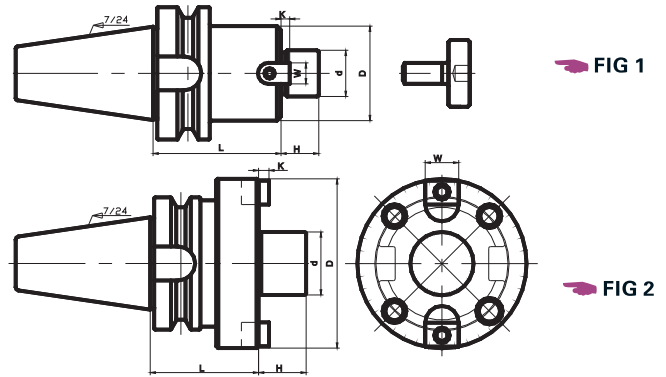

注：B型使用大頭鎖緊螺絲，C型使用小頭鎖緊螺絲。  
The B model uses a big clamping nut, The C model uses a small clamping nut.

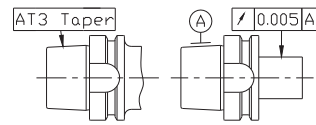

訂貨型號 Order Code	圖號 FIG	L	ød(h6)	øD	H	K	W	重量(Kg) Weight
BT30-FMB ( C ) 22-45	1	45	22	48	18	5	10	0.8
-100		100						1.5
-FMB ( C ) 27-60		60	27	60	20	6	12	1.4
-FMB ( C ) 32-60			32	72	22	7	14	1.8
BT40-FMB ( C ) 22-45	1	45	22	48	18	5	10	1.4
-60		60						1.6
-90		90						1.8
-105		105						2.2
-150		150						2.9
-200		200						3.6
-FMB ( C ) 27-45		45	27	60	20	6	12	1.6
-60			60	2.0				
-105			105	3.0				
-FMB ( C ) 32-45		45	32	72	22	7	14	1.9
-60			60	2.3				
-FMB ( C ) 40-70		70	40	80	25	8	16	2.9
-FMB ( C ) 40F-60			110	2.8				
-FMB ( C ) 40M-60			89.3	2.3				
BT50-FMB ( C ) 22-60	1		60	22	48	18	5	10
-105		105	4.6					
-150		150	5.5					
-200		200	6.1					
-250*		250	6.8					
-300*		300	7.5					
-350*		350	10.7					

注：帶“\*”規格為加長型非標產品，如有需要請致電本司諮詢。  
The "\*" model is for extension types, it is not a standard product, please order them additionally if necessary.

續表>>  
Continu

